

43000 Series Double Stack Size 17 Hybrid Linear Actuators

Exceptional performance and new linear motion design opportunities

The 43000 Series is available in a wide variety of resolutions from 0.000625-in (.0158 mm) per step to 0.005-in (.127 mm) per step. The motors can also be microstepped for even finer resolutions. The Size 17 Double Stack actuator delivers thrust of up to 75 lbs. (337 N).

3 Available Designs

- Captive
- Non-Captive
- External Linear

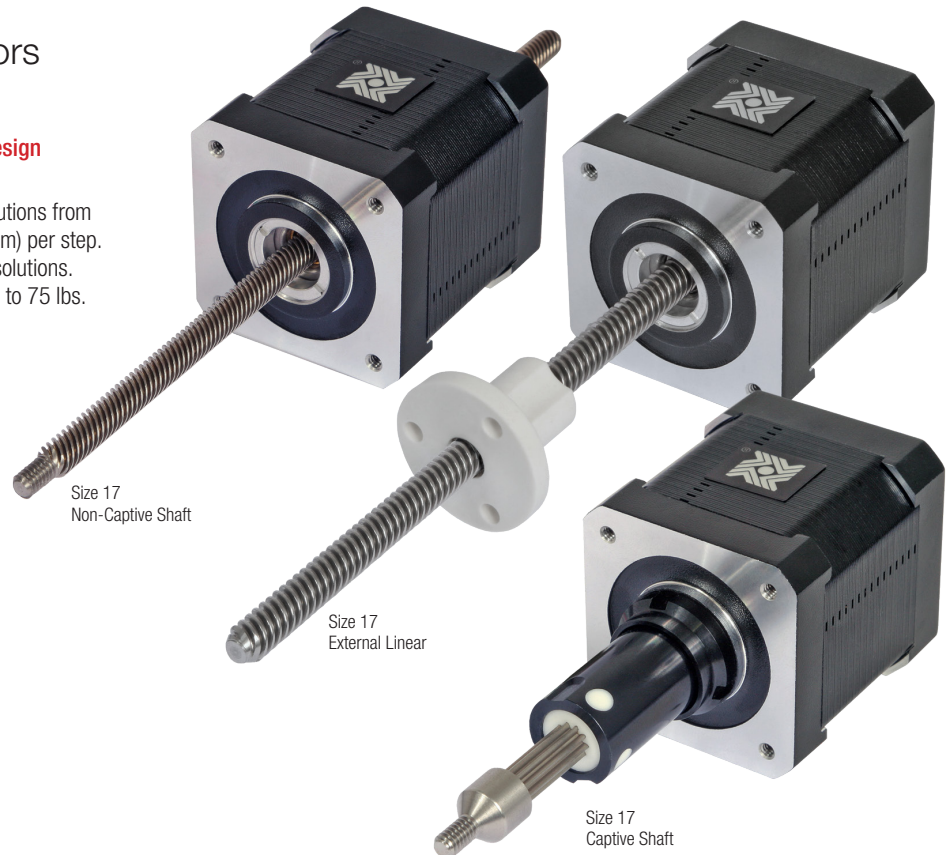

Size 17 Double Stack: 43 mm (1.7-in) Hybrid Linear Actuator (1.8° Step Angle)

Part No.	Captive	43M4 ■ – ■ – ■ ■ †		
	Non-Captive	43L4 ■ – ■ – ■ ■ †		
	External Linear	E43M4 ■ – ■ – ■ ■ †		
Wiring	Bipolar			
Winding Voltage	2.33 VDC	5 VDC	12 VDC	
Current (RMS)/phase	2.6 A	1.3 A	550 mA	
Resistance/phase	0.9 Ω	3.8 Ω	21.9 Ω	
Inductance/phase	1.33 mH	8.21 mH	45.1 mH	
Power Consumption	13.2 W			
Rotor Inertia	78 gcm ²			
Insulation Class	Class B (Class F available)			
Weight	12.5 oz (352 g)			
Insulation Resistance	20 MΩ			

Linear Travel / Step		Order Code I.D.
Screw Ø.1875" (4.76mm)		
inches	mm	
.000625	.0158*	B
.00125	.0317*	C
.0025	.0635	Y
.00375	.0953	AG
.005	.127	Z

*Values truncated.

Standard motors are Class B rated for maximum temperature of 130°C.

Special drive considerations may be necessary when leaving shaft fully extended or fully retracted.

†Part numbering information on page 6.

Captive Lead Screw

Dimensions = (mm) inches

Integrated connector option available

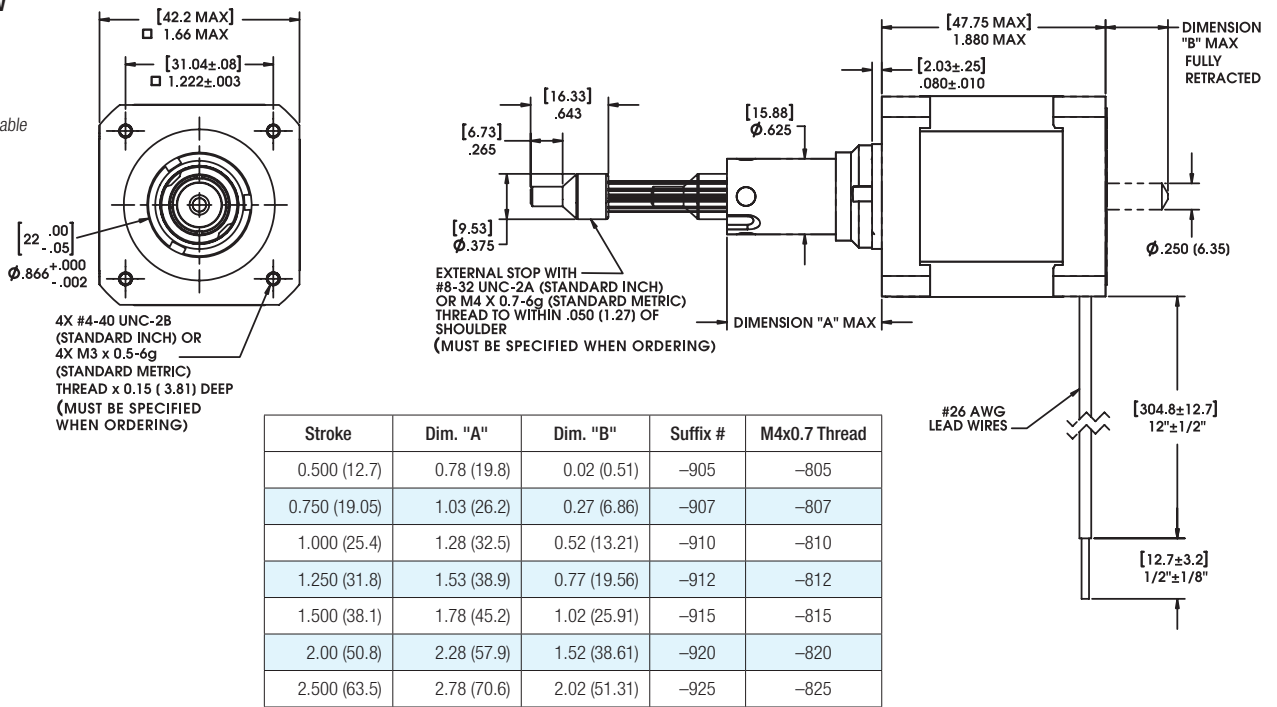

Non-Captive Lead Screw

Dimensions = (mm) inches

Integrated connector option available

4-in [101.6 mm] standard screw lengths. Longer screw lengths are available.

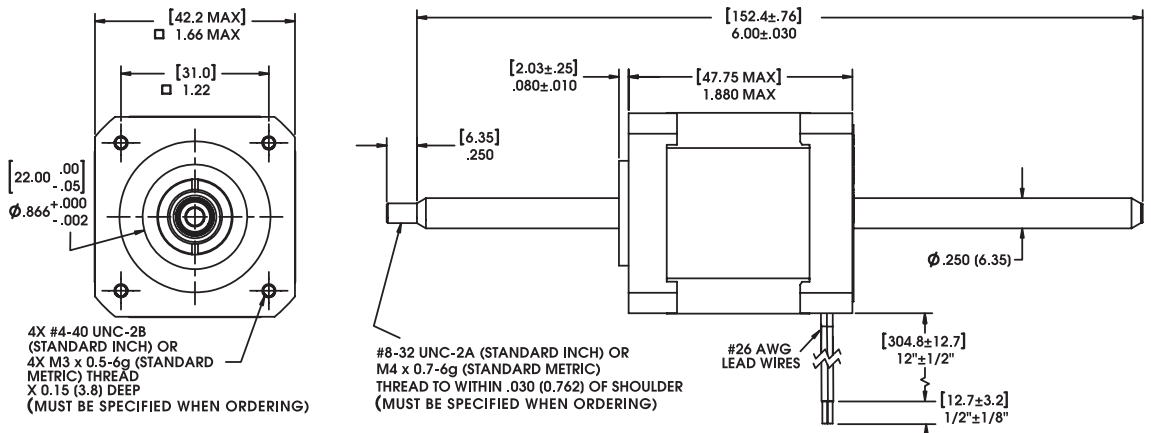

External Linear

Dimensions = (mm) inches

Integrated connector option available

4-in [101.6 mm] standard screw lengths. Longer screw lengths are available.

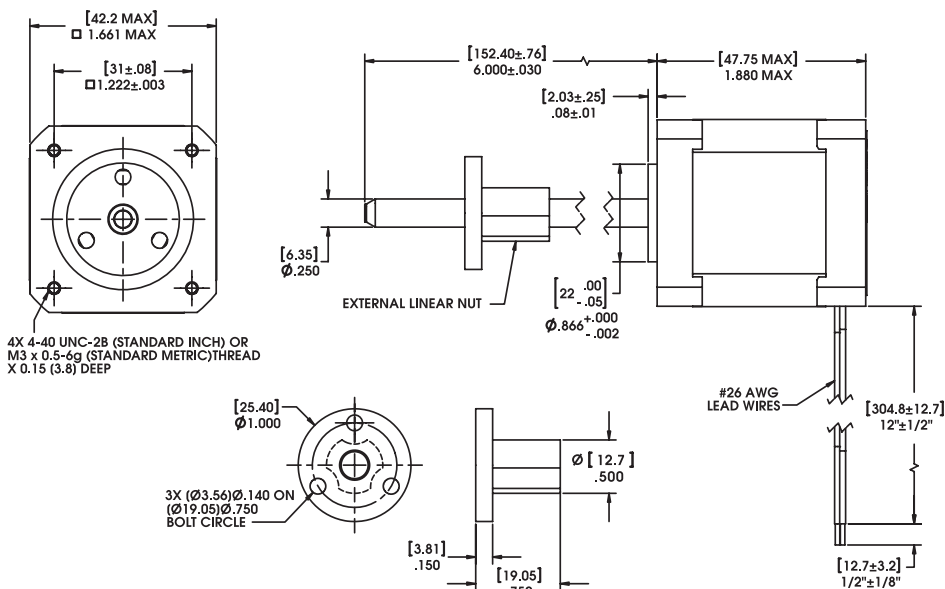

FORCE vs. PULSE RATE – Chopper – Bipolar – 100% Duty Cycle – 8:1 Motor Coil to Drive Supply Voltage

– Ø .250 (6.35) Lead Screw

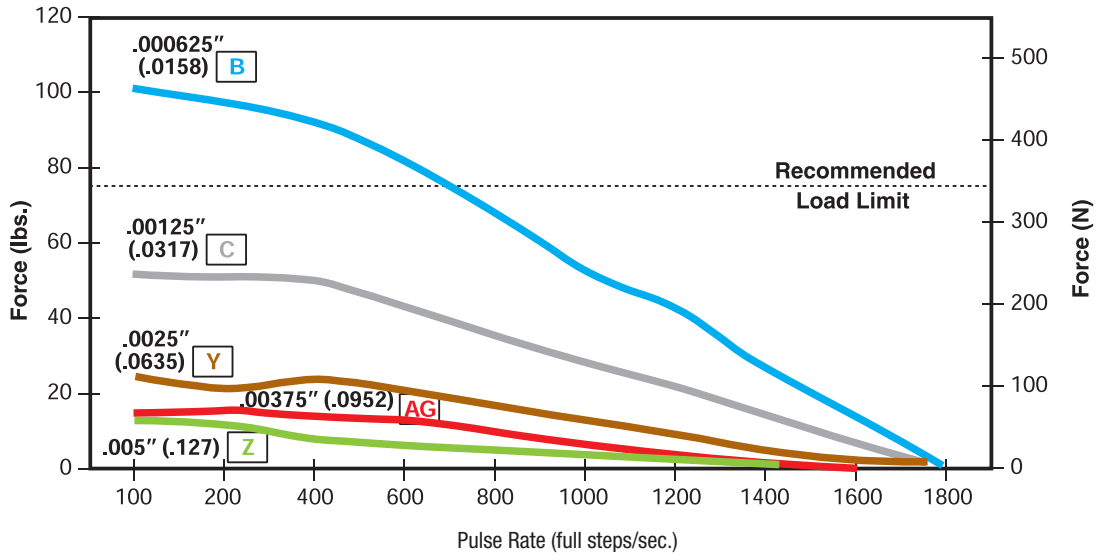

FORCE vs. LINEAR VELOCITY – Chopper – Bipolar – 100% Duty Cycle – 8:1 Motor Coil to Drive Supply Voltage

– Ø .250 (6.35) Lead Screw

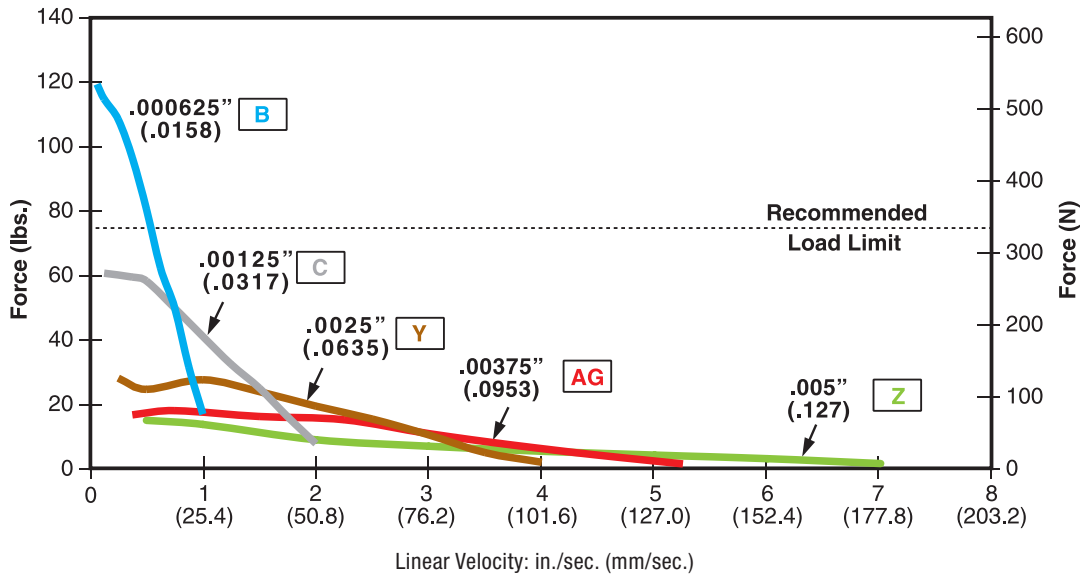

NOTE: All chopper drive curves were created with a 5 volt motor and a 40 volt power supply.

Ramping can increase the performance of a motor either by increasing the top speed or getting a heavier load accelerated up to speed faster. Also, deceleration can be used to stop the motor without overshoot.

With L/R drives peak force and speeds are reduced, using a unipolar drive will yield a further 30% force reduction.

43000 Series Size 17 Double Stack Hybrid Linear Actuators with integrated IDEA™ Drive

High performance in a compact package

The 43000 Series Double Stack actuator is available in a wide variety of resolutions – from 0.000625-in (.0158 mm) per step to 0.005-in (.127 mm) per step. Delivers output force of up to 75 lbs (337N).

43000 Series with IDEA™ Drive features:

- Fully Programmable
- RoHS Compliant
- USB or RS-485 Communication
- Microstepping Capability: Full, 1/2, 1/4, 1/8, 1/16, 1/32, 1/64
- Graphic User Interface
- Auto-population of Drive Parameters
- Programmable Acceleration/Deceleration and Current Control

3 Available Designs

- Captive – Non-Captive – External Linear



Size 17
Captive Shaft

Size 17
Non-Captive Shaft

Size 17
External Linear

Size 17 Double Stack: 43 mm (1.7-in) Hybrid Linear Actuator (1.8° Step Angle)		
Part No.	Captive	43MG – – – †
	Non-Captive	43LG – – – †
	External Linear	E43MG – – – †
Wiring	Bipolar	
Winding Voltage	2.33 VDC**	

Linear Travel / Step		Order Code I.D.
Screw Ø .250" (6.35 mm)		
inches	mm	
.000625	.0158*	B
.00125	.0317*	C
.0025	.0635*	Y
.00375	.0953*	AG
.005	.127*	Z

†Part numbering information on page 7. **Contact Haydon Kerk if a higher voltage motor is desired. Special drive considerations may be necessary when leaving shaft fully extended or fully retracted.

Simple to use IDEA™ Drive software with on-screen buttons and easy-to-understand programming guides

Software program generates motion profiles directly into the system and also contains a “debug” utility allowing line-by-line execution of a motion program for easy troubleshooting.

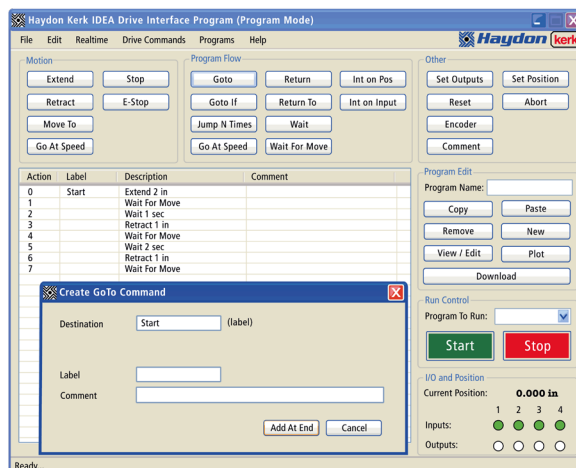

Captive Lead Screw

Dimensions = (mm) inches

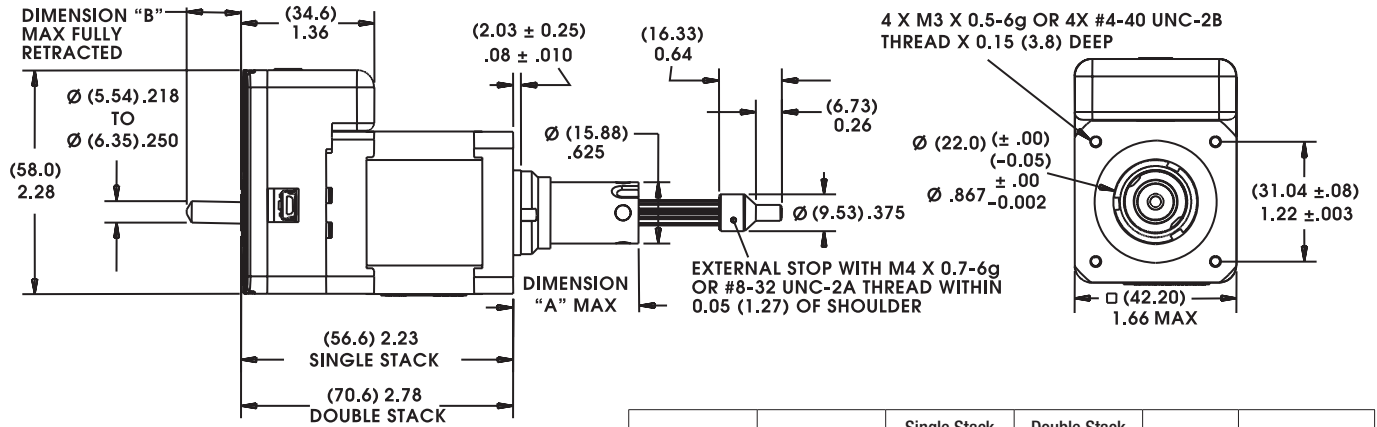

Stroke	Dim. "A"	Single Stack Dim. "B"	Double Stack Dim. "B"	Suffix #	M4x0.7 Thread
0.500 (12.7)	0.78 (19.8)	0	0	-905	-805
0.750 (19.05)	1.03 (26.2)	0	0	-907	-807
1.000 (25.4)	1.28 (32.5)	0	0	-910	-810
1.250 (31.8)	1.53 (38.9)	0	0	-912	-812
1.500 (38.1)	1.78 (45.2)	0.232 (5.9)	0.091 (2.5)	-915	-815
2.00 (50.8)	2.28 (57.9)	0.732 (18.6)	0.591 (15.0)	-920	-820
2.500 (63.5)	2.78 (70.6)	1.232 (31.3)	1.091 (27.7)	-925	-825

Non-Captive Lead Screw

Dimensions = (mm) inches

Up to 10-in (254 mm) standard screw lengths. Longer screw lengths are available.

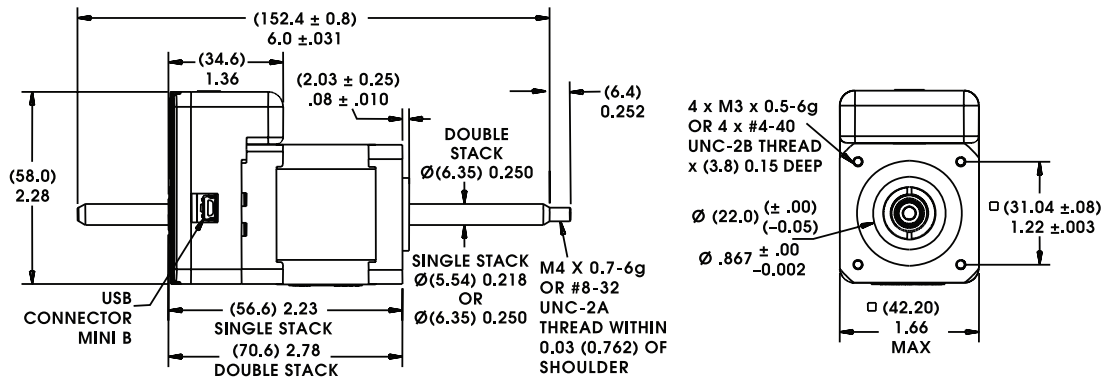

External Linear

Dimensions = (mm) inches

Up to 10-in (254 mm) standard screw lengths. Longer screw lengths are available.

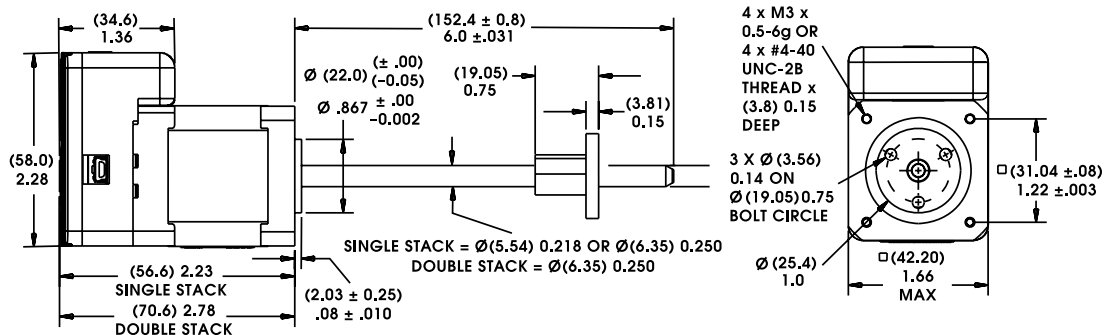

Identifying the Hybrid Part Number Codes when Ordering

E	43	M	G	C	2.33	910
Prefix (include only when using the following) A = A Coil (See AC Synchronous Data Sheet) E = External K = External with 40° thread form P = Proximity Sensor S = Home Position Switch	Series Number Designation 43 = 43000 (Series numbers represent approximate width of motor body)	Style L = 1.8° Non-captive M = 1.8° Captive or External (use "E" or "K" Prefix for External version)	Coils 4 = Bipolar (4 wire) G = IDEA Drive (Size 17, 43000 Series, Bipolar only)	Code ID Resolution Travel/Step B = .000625-in (.0158) C = .00125-in (.0317) Y = .0025-in (.0635) AG = .00375-in (.0953) Z = .005-in (.127)	Voltage 2.33 = 2.33 VDC 05 = 5 VDC 12 = 12 VDC Custom V available	Suffix Stroke Example: -910 = 1-in (Refer to Stroke chart on Captive motor series product page.) Suffix also represents: -800 = Metric -900 = External Linear with grease and flanged nut -XXX = Proprietary suffix assigned to a specific customer application. The identifier can apply to either a standard or custom part.

NOTE: Dashes must be included in Part Number (-) as shown above. For assistance call our Engineering Team at 203 756 7441.

Hybrids: **Wiring**

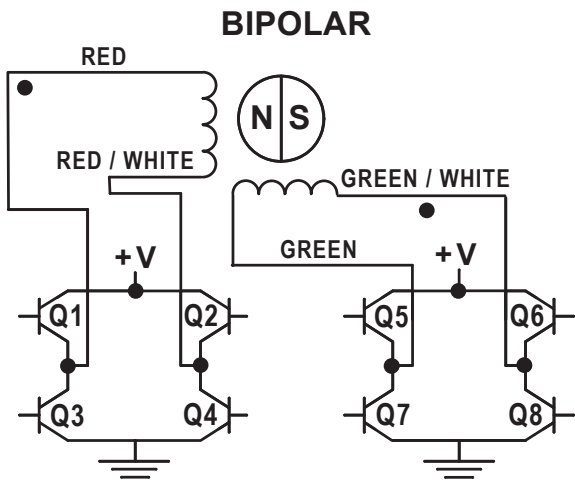

Hybrids: **Stepping Sequence**

Bipolar	Q2-Q3	Q1-Q4	Q6-Q7	Q5-Q8
Step				
1	ON	OFF	ON	OFF
2	OFF	ON	ON	OFF
3	OFF	ON	OFF	ON
4	ON	OFF	OFF	ON
1	ON	OFF	ON	OFF

EXTEND CW ↓ RETRACT CCW ↑

Note: Half stepping is accomplished by inserting an off state between transitioning phases.

Encoders Designed for All Sizes of Hybrid Linear Actuators

All Haydon Hybrid Linear Actuators are available with specifically designed encoders for applications that require feedback. The compact optical incremental encoder design is available with two channel quadrature TTL squarewave outputs. An optional index is also available as a 3rd channel. The Size 17 Encoder provides resolutions for applications that require 200, 400 and 1,000 counts per revolution. Encoders are available for all motor configurations.

Simplicity and low cost make the encoders ideal for both high and low volume motion control applications. The internal monolithic electronic module converts the real-time shaft angle, speed, and direction into TTL compatible outputs. The encoder module incorporates a lensed LED light source and monolithic photodetector array with signal shaping electronics to produce the two channel bounceless TTL outputs.

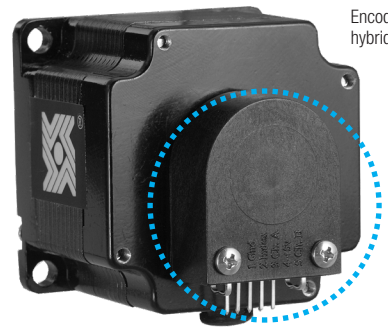

Encoder on Size 23 hybrid motor

30 mm 43000 Series Size 17

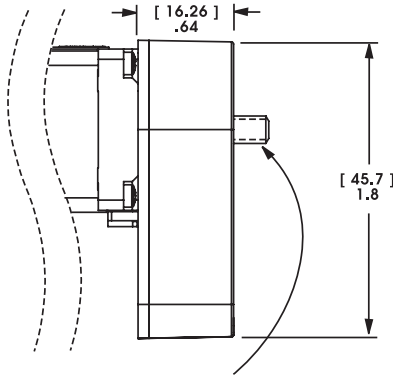

NOTE: Lead Screw extends beyond encoder on specific captive and non-captive motors. External linear shaft extension is available upon request.

Differential Ended Encoder - Pinout - Size 17	
Connector Pin #	Description
1	Ground
2	Ground
3	- Index
4	+ Index
5	Channel A -
6	Channel A +
7	+5 VDC Power
8	+5 VDC Power
9	Channel B -
10	Channel B +

Electrical Specifications				
	Minimum	Typical	Maximum	Units
Input Voltage	4.5	5.0	5.5	VDC
Output Signals	4.5	5.0	5.5	VDC

2 channel quadrature TTL squarewave outputs.
 Channel B leads A for a clockwise rotation of the rotor viewed from the encoder cover.
 Tracks at speeds of 0 to 100,000 cycles/sec.
 Optional index available as a 3rd channel (one pulse per revolution).

Operating Temperature		
Size 17	Minimum	Maximum
	- 40°C (- 40°F)	100°C (212°F)

Mechanical Specifications	
	Maximum
Acceleration	250,000 rad/sec ²
Vibration (5 Hz to 2 kHz)	20 g

Resolution				
4 Standard Cycles Per Revolution (CPR) or Pulses Per Revolution (PPR)				
Size 17	CPR	200	400	1000*
	PPR	800	1600	4000*

*Index Pulse Channel not available.

Single Ended Encoder - Pinout - Size 17			
Connector Pin #	Description	Connector Pin #	Description
1	Ground	4	+5 VDC Power
2	Index (optional)	5	Channel B
3	Channel A		

Integrated Connectors

Hybrid Size 17 linear actuators are available with an integrated connector. Offered alone or with a harness assembly, this connector is RoHS compliant and features a positive latch in order for high connection integrity. The connector is rated up to 3 amps and the mating connector will handle a range of wire gauges from 22 to 28. This motor is ideal for those that want to plug in directly to pre-existing harnesses.

Motor Connector:

JST part # S06B-PASK-2

Mating Connector:

JST part # PAP-06V-S

Haydon Kerk Part #56-1210-5 (12 in. Leads)

Wire to Board Connector:

JST part number SPHD-001T-P0.5

Pin #	Bipolar	Unipolar	Color
1	Phase 2 Start	Phase 2 Start	G/W
2	Open	Phase 2 Common	-
3	Phase 2 Finish	Phase 2 Finish	Green
4	Phase 1 Finish	Phase 1 Finish	R/W
5	Open	Phase 1 Common	-
6	Phase 1 Start	Phase 1 Start	Red

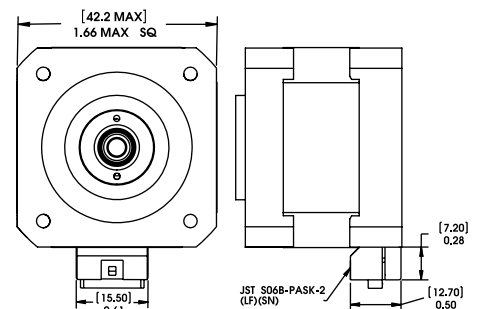

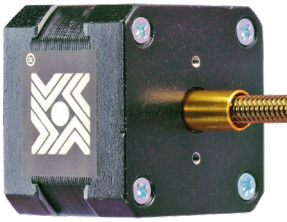

Encoder Ready Option Shown 34000 Series Size 17

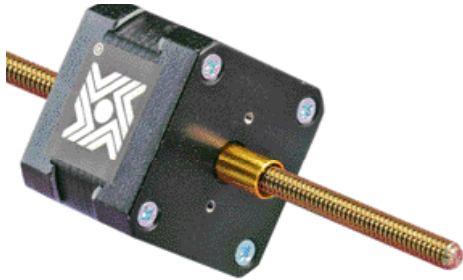

Extended Rotor Journal Shown 34000 Series Size 17

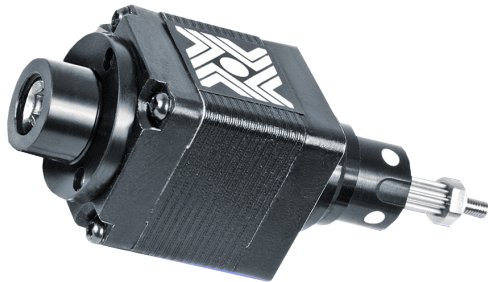

End of Stroke Proximity Sensor



TFE Coated Lead Screw



Integrated Anti-Backlash Nut

Encoder Ready Option for all Hybrid Sizes

Our Hybrid Linear Actuators can now be manufactured as an Encoder Ready Actuator. Encoder Ready Actuators can be used to install several popular hollow shaft encoders. Available with an extended rotor journal and a threaded rear housing. The motor uses a proprietary manufacturing process which incorporates engineering thermoplastics in the rotor drive nut and a stainless steel Acme Lead Screw that allows the motor to be much more efficient and durable than today's more commonly used V-thread bronze nut configurations.

Size 23 Mounting Face Plate for Size 17 Hybrids

Size 23 mounting pattern for our Hybrid Size 17 Linear Actuators.

Extended Rotor Journal for all Hybrid Sizes

Available with an extended rotor journal. The extended rotor journal can be used for encoder installation, manual adjustment, or flag installation for a positioning sensor.

Home Position Switch for Hybrids

A miniature electronic Home Position Switch capable of monitoring the home positions of linear actuators. The switch mounts on the rear sleeve of captive linear motors and allows the user to identify start, stop or home positions.

When ordering motors with the home position switch the part number should be preceded by an "S" prefix.

End of Stroke Proximity Sensor for all Hybrid Sizes

The Sensor incorporates a hall effect device, which is activated by a rare earth magnet embedded in the end of the internal screw. The compact profile of the sensor allows for installation in limited space applications. The sensor has a virtually unlimited cycle life. Special cabling and connectors can also be provided.

When ordering motors with the proximity sensor, the part number should be preceded by a "P" prefix.

Black Ice® and Kerkote® TFE Coated Lead Screws*

TFE Coated Lead Screws for applications that require a *greaseless* screw and nut interface.

A *dry* (non-lubricated) TFE coated lead screw provides improved performance in both life and thrust as compared to a conventional stainless steel lead-screw. TFE can be applied to a wide variety of lead-screw pitches and is available for our brand captive, non-captive and external linear actuators. Not available for 0.00006-in (.0015 mm) and 0.000098-in (.0025 mm) resolutions.

*Certain conditions apply.

Integrated Anti-Backlash Nut for Hybrids*

Most sizes (except Size 34) of our captive and non-captive hybrid stepper motors can be equipped with an integral anti-backlash feature. There is a normal backlash between the lead screw and integral rotor nut.

Our actuators are designed for millions of cycles. However over time, additional backlash could increase and eventually double. Haydon Kerk Integrated Anti-Backlash Nut can eliminate all backlash. Designed specifically for our captive and non-captive hybrid motors, nuts use an opposing spring force to eliminate backlash between the screw and the nut interface. The nuts will self-compensate and accommodate any wear. Haydon Kerk Motion Solutions application engineers can help you select the appropriate preload for your application.

*Except Size 34.