

DATA SHEET

MV311

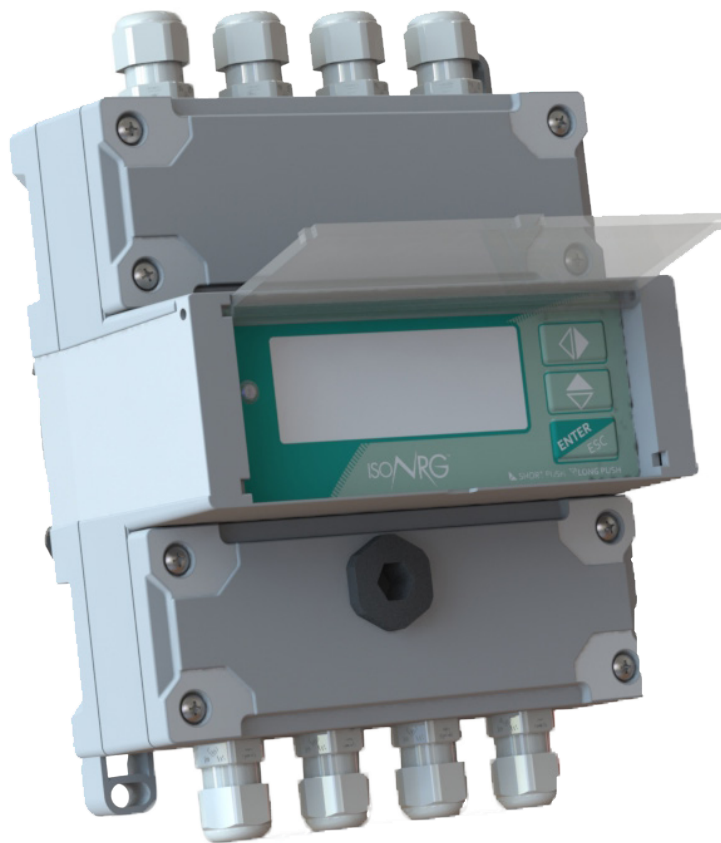

CE



INDEX

SYSTEM DESCRIPTION	3
TECHNICAL DATA	5
OVERALL DIMENSIONS	7
MV311 CONSTRUCTION	8
PAGES VISUALIZATION	9
ELECTRICAL CONNECTIONS	10
DIGITAL INPUTS	11
ANALOG INPUTS	12
DIGITAL OUTPUTS	13
ANALOG OUTPUTS	13
POWER SUPPLIES	14
FUNCTIONS MENU	15
HOW TO ORDER	20

SYSTEM DESCRIPTION

MV311 is an energy meter designed for heating, cooling or combined heating/cooling carried by a thermal fluid; typically the thermal fluid is water, though a special features allow to calculate the energy even for water and glycol ethylene or polypropylene at several concentration. The calculator contains all the necessary circuits for calculating energy value according to the standard EN1434; the thermal energy calculation is based on the following calculation :

$$\dot{Q}$$

Where:

- Q: amount of heat (energy) transferred or absorbed
- q_m : mass flow rate of the vector fluid /kg s-1
- Δh : Δ of specific enthalpy between in-let and out-let pipe line /J kg-1
- t: time /s

So, the quantities to be measured are the the heat transfer fluid flow rate and the two temperatures of the circuit, measured respectively on a suitable flow and return point of the fluid itself.

Flow measurement

The calculator can calculate the flow rate throughout two channel:

- Analogic: it acquires the 4-20mA signal from a flow meter
- Factorized pulses: it calculates the flow rate throughout factorized pulses coming from the flow meter

Temperature measurement

The instrument measures the temperature by RTD (PT type), in a 4-wires configuration; the PT values, can be selected via software; the allowed model are:

- PT100
- PT500
- PT1000

By a highly accurate internal reference system and an appropriate electronic switch network, the temperatures are measured by highly accurate ADC (Analog to Digital Converter).

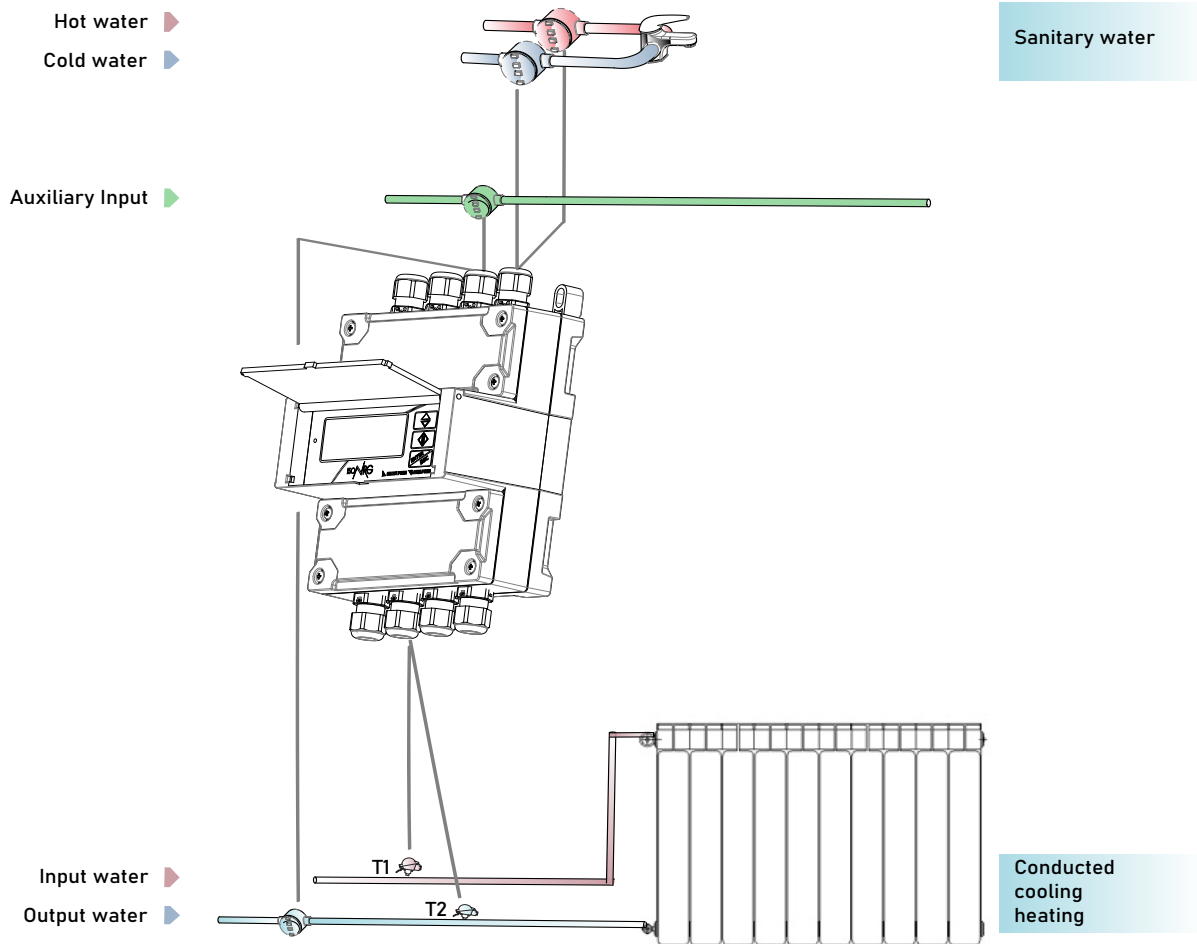

The diagram is a schematic of the principle: in addition to the thermal energy meter function, the MV 311 allows to totalize hot and cold water volume used for service lines; in some cases this solution can be helpful for a quick reference of the measures and the possibility to transfer them to other systems using several fieldbus which the instrument has built-in.

TECHNICAL DATA

OVERALL FEATURES	
Maximum Thermal Power	<input type="checkbox"/> Ps = 99999 GW
Hot/Cold Switching	<input type="checkbox"/> Automatic through assignment of the +/- sign (possibility of congruence control from remote input)
Measure Units Available	<input type="checkbox"/> kW/MJ, W, kW, MW, GW, J, kJ, Wh, Mj, kWh, Gj, MWh, GWh, BTU, kBTU, MBTU, °C, °F, ml, cm3, l, dm3, dal, hl, m3, Ml, in3, Gal, IGL, ft3, bbl, BBL, hf3, KGL, IKG, kf3, ttG, Aft, MGL, IMG,
Installation	<input type="checkbox"/> Any orientation - DIN rail
Altitude	<input type="checkbox"/> From -200m to 4000m (from -656 to 13120 feet)
Environmental Temperature	<input type="checkbox"/> +5... +55°C (+41...+131°F)
Temperature Range(Measure)	<input type="checkbox"/> -30... +200 (-22...+392°F) <input type="checkbox"/> -15... +150 (+5...+302°F) for MID instrument
Protection Rate	<input type="checkbox"/> IP65
STANDARD FEATURES	
Housing Material	<input type="checkbox"/> PC/ABS self-extinguishing
Power Supply/Power Consumption	<input type="checkbox"/> 100-240V~ 45-66Hz (5W); 24-36V~ 45-66Hz --- (5W); 12-48V (5W)
Pulses Outputs	<input type="checkbox"/> N° 2 output 1250Hz, 100mA, 30Vdc
Available Protocols	<input type="checkbox"/> MCP over USB
Digital Input	<input type="checkbox"/> N° 1 multifunction (Reset totalizers, cooling, heating, auxiliary fluid volume)
Analog Input For Flow Meter	<input type="checkbox"/> N°1 4..20mA range for measure fluid flow rate
Pulses Inputs (q max weight function per pulse)	<input type="checkbox"/> N° 4 inputs (frequency max. 1kHz, min. 0.003 Hz): <input type="checkbox"/> Vector Fluid volume <input type="checkbox"/> Hot water volume <input type="checkbox"/> Cold water volume <input type="checkbox"/> Auxiliary fluid volume (or digital input)
Inputs For Sensor Temperature	<input type="checkbox"/> N° 2 (one for the delivery and one for the return)
Digital Outputs	<input type="checkbox"/> N° 2 programmable for alarms or pulses for energy/volume
Programming Plug In	<input type="checkbox"/> Mini USB type B
Data storage	<input type="checkbox"/> F-RAM: permanent data storage in case of power failure
Galvanic Isolation	<input type="checkbox"/> All the inputs/outputs are galvanically isolated from power supply up to 500 V
Diagnostic Function	<input type="checkbox"/> Yes
CE Certification	<input type="checkbox"/> Yes

OPTIONAL FEATURES**(CHECK FOR MORE DETAILS 'HOW TO ORDER' ON LAST PAGE)**

LCD Display	<input type="checkbox"/> Graphic display 128 x 48 pixels back light; characters height 7,2/3,6mm <input type="checkbox"/> 3 membrane keys <input type="checkbox"/> Led status
Current Output	<input type="checkbox"/> N° 2 0/4...20mA selectable alternatively for flow, power, temperature T1, T2 or delta T
Temperature Sensor	<input type="checkbox"/> Thermal probes PT 100/PT500/PT1000 (2/3/4 wires)
Communication Port	<input type="checkbox"/> RS 485/MBus
Available Protocols	<input type="checkbox"/> Modbus (over RS485)/ BACnet (over RS485)/ M-bus 
Data Storage	<input type="checkbox"/> Data Logger with MicroSD Memory 4 GB
RTC	<input type="checkbox"/> Real Time Clock with Autonomy of 7 days (1 month if Measure Backup battery is installed) in absence of power supply.
Measure Backup	<input type="checkbox"/> Rechargeable Li-ion Battery for Measure Backup operations up to 1 month in absence of power supply (depending on configurations and connections).
MID Certification	<input type="checkbox"/> MI-004
MEASUREMENT	
Temperature Measuring Range	<input type="checkbox"/> ϑ_{min} -15 °C (+5°F), ϑ_{max} 200°C (392°F)
Delta Temperature ($\Delta\vartheta$)	<input type="checkbox"/> $\Delta\vartheta$ min 3 °C (37,4°F), $\Delta\vartheta$ max 150 °C (392°F) <input type="checkbox"/> $\Delta\vartheta$ min 0,1 °C (32.18°F) $\Delta\vartheta$ max 200 °C (392°F) – instruments without MID certificate
Measurement Accuracy	<input type="checkbox"/> System: $\pm 0,20\%$ ($0.18 + \Delta\vartheta_{min}/\Delta\vartheta$)

OVERALL DIMENSIONS

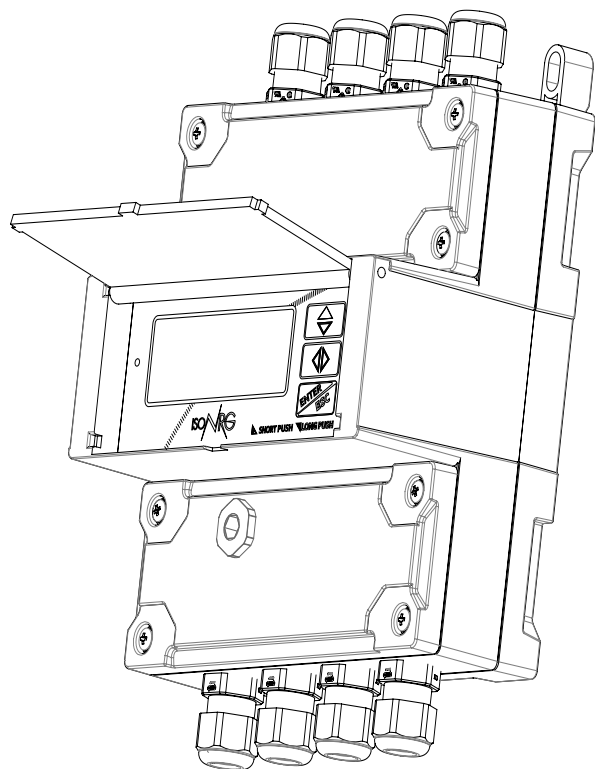
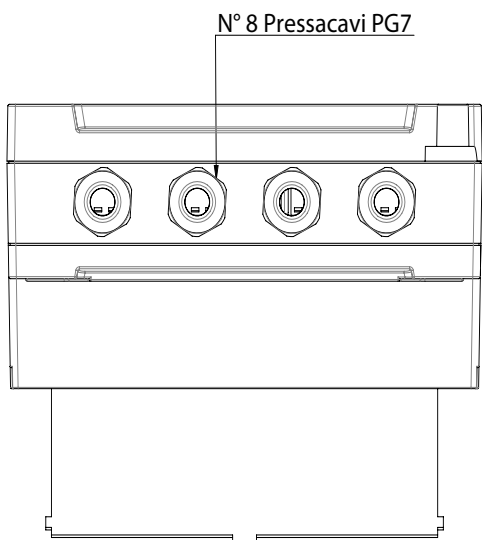
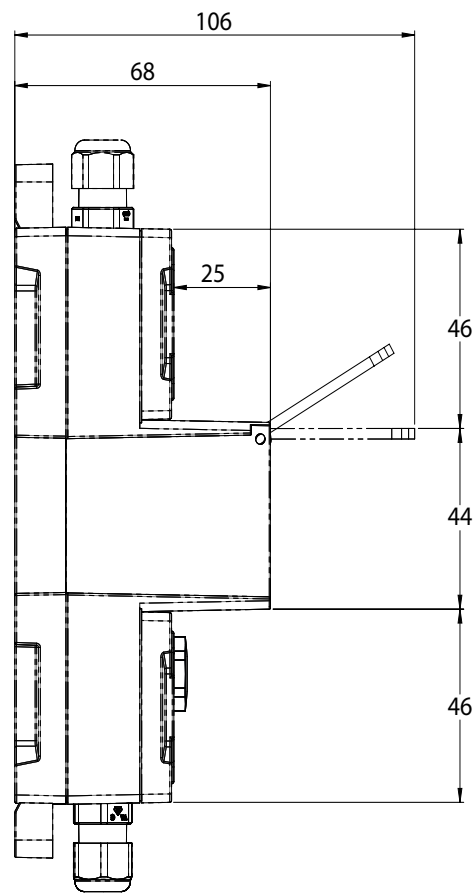
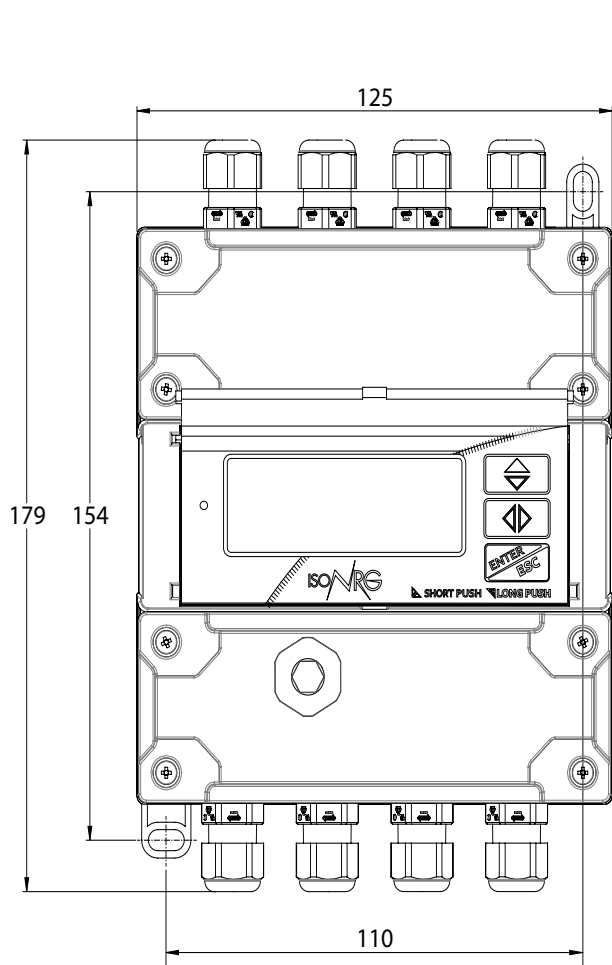

MV311 CONSTRUCTION

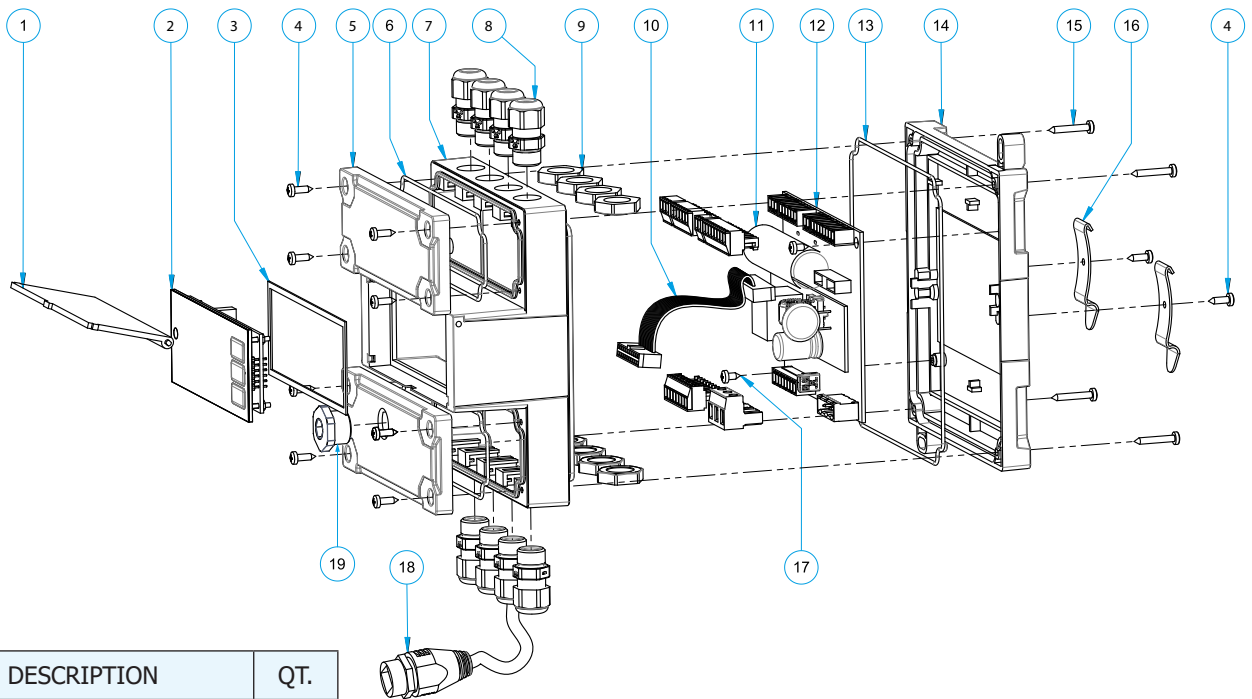

POS.	DESCRIPTION	QT.
1	PROTECTION GLASS	1
2	MV311 DISPLAY	1
3	ADHESIVE GASKET	1
4	SELF-TAPPING SCREW 2.9X9.5	10
w	TERMINAL BLOCK COVER	1
6	O-RING TERMINAL BLOCK COVER	2
7	MAIN HOUSING	2
8	CABLE GLAND PG7 COMPLETE WITH O-RING	8
9	CABLE GLAND RING PG7	8
10	FLAT CABLE 20 VIE	1
11	MV311 BATTERY	1
12	MV311 PCB	1
13	O-RING BACK COVER	1
14	REAR COVER	4
15	SELF-TAPPING SCREW 2.9X19	2
16	DIN RAIL CONNECTIONS	2
17	SELF-TAPPING SCREW 2.9X6.5	1
18	OPTIONAL ETHERNET CONNECTOR (P.O.E. ON ORDER).	1
19	PG9 CAP	1

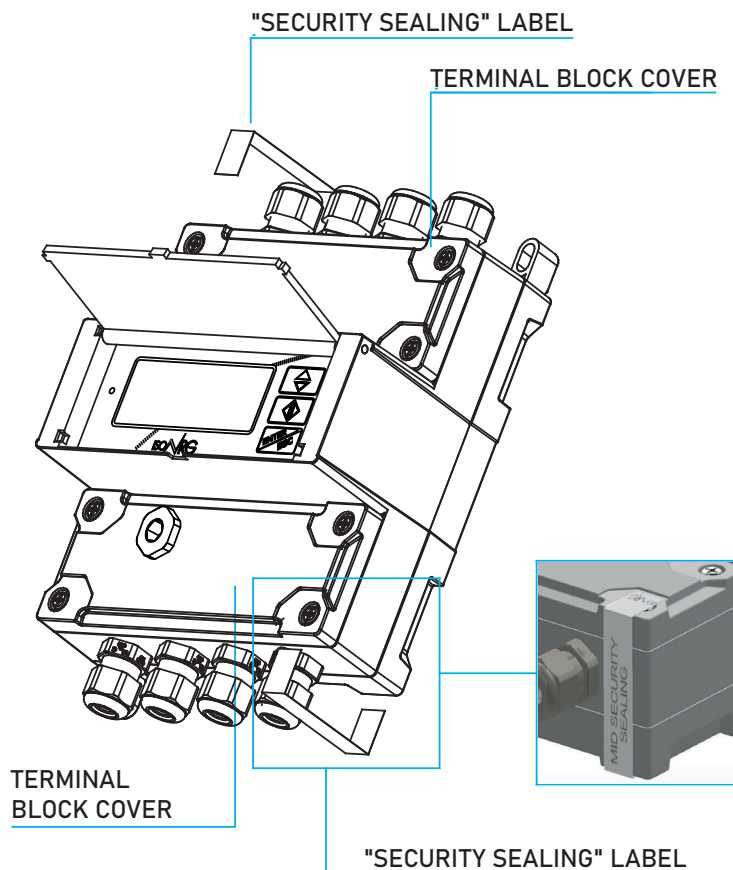

The manufacturer guarantees only English text available on our web site www.isoil.com

PAGES VISUALIZATION

Different visualization possibilities by simply pressing of a key.

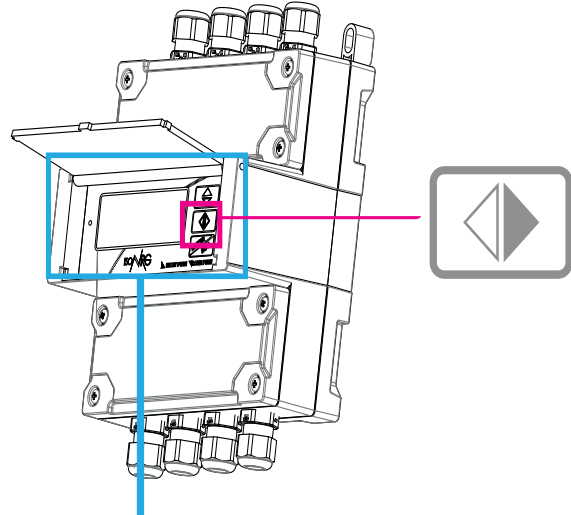

NO ALARMS 2018/03/07 09:28	POWER & FLOW ThPwr kW ▲ 1.4 UF 1/h ▼ 775.3 2018/05/25 13:29:59	TEMPERATURES TD °C +3.02 T1 °C 26.28 T2 °C 23.26 2018/03/07 09:28:32
HEATING ENERGY T. kWh 4.6460583 P. kWh 4.6460583 2018/03/07 09:28:34	COOLING ENERGY T. kWh 0.0000000 P. kWh 0.0000000 2018/03/07 09:28:35	DECTOR FILL T. m³ 0.1012744 P. m³ 0.1012744 2018/03/07 09:28:37
HOT SERU. NUMBER T. m³ 0.0969618 P. m³ 0.0969618 2018/03/07 09:28:40	COLD SERU. NUMBER T. m³ 0.0969618 P. m³ 0.0969618 2018/03/07 09:28:41	SUMMARY MENU T. ml 0.00 P. ml 0.00 2020/04/23 09:22:52
MAIN POWER SUPPLY OFF 2018/03/07 09:35:11		

ELECTRICAL CONNECTIONS

Cable gland PG7:
Allowed diameter
cables 3-6.5 mm.

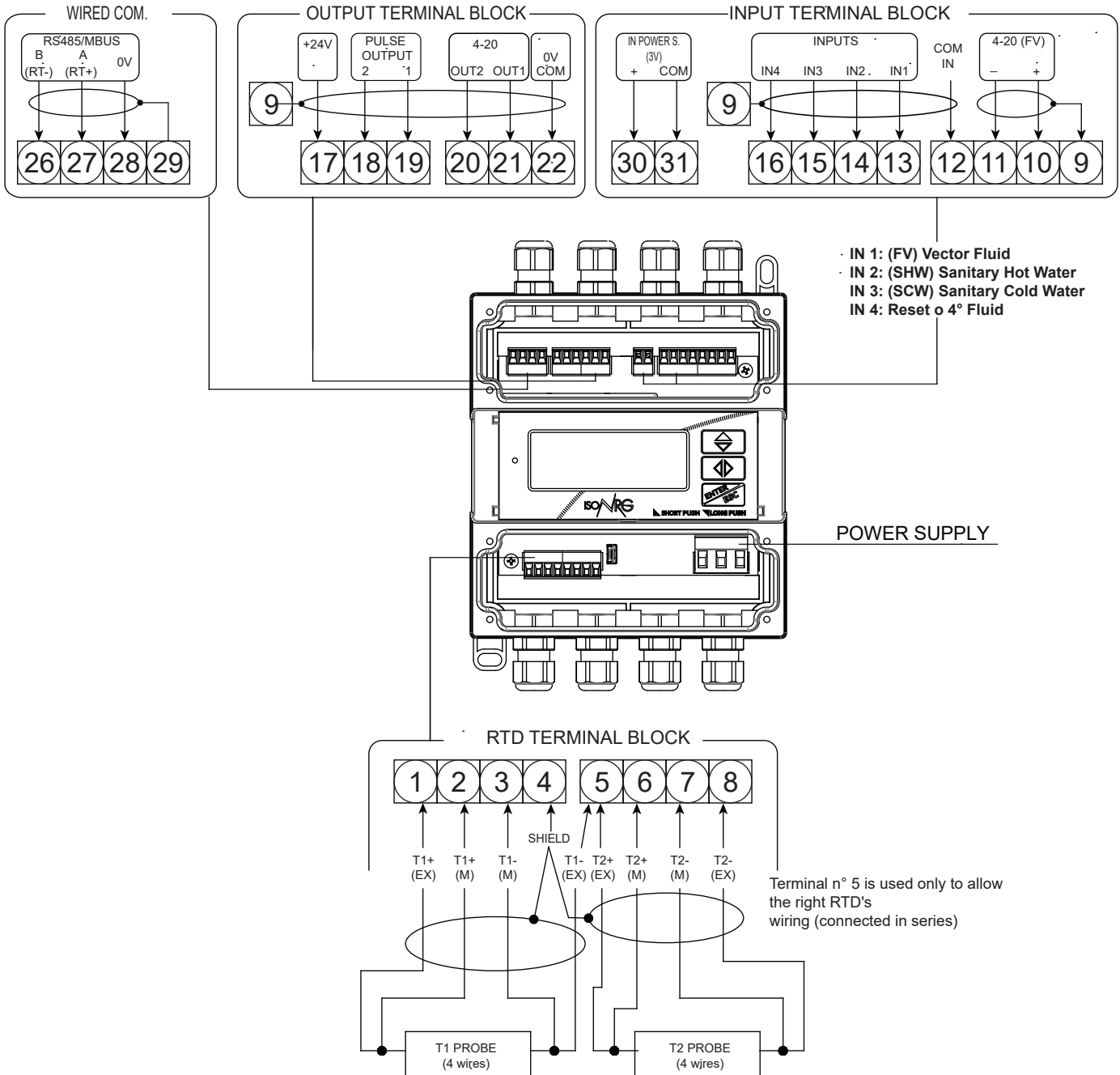

Terminal n° 5 is used only to allow the right RTD's wiring (connected in series)

To connect 2 wire probe:
 T1: connect the probe to terminal block 2 and 3, bridge on 1-2 and 3-5
 T2: connect the probe to terminal block 6 and 7, bridge on 5-6 and 7-8

The manufacturer guarantees only English text available on our web site www.isoil.com

DIGITAL INPUTS

Connections with polarity type "P"

Isolated digital input with external power supply

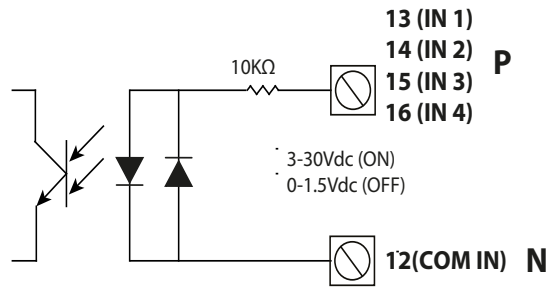

Isolated digital input with + 24V internal power supply

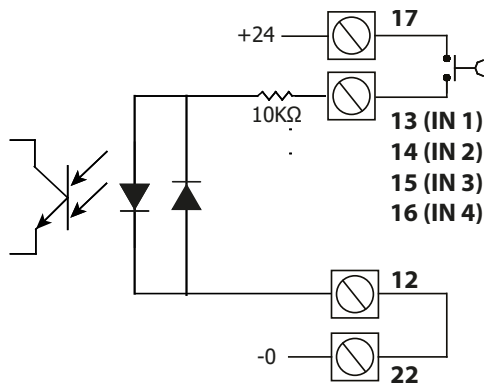

Not isolated digital input with internal battery power supply

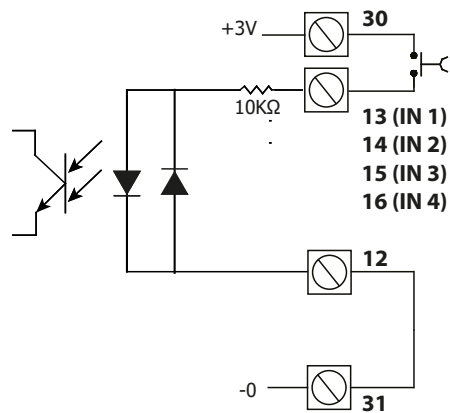

Connections with polarity type "N"

Isolated digital input with external power supply

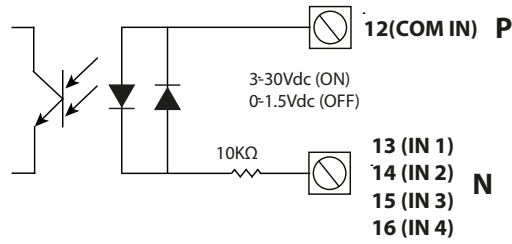

Digital input with + 24V internal power supply

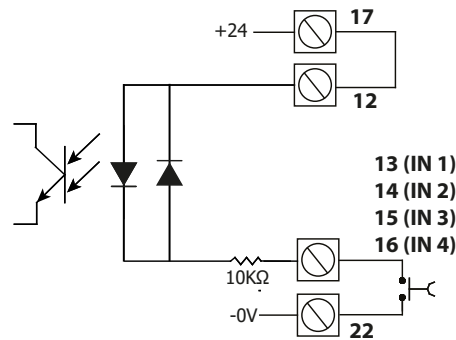

Not isolated digital input with internal battery power supply

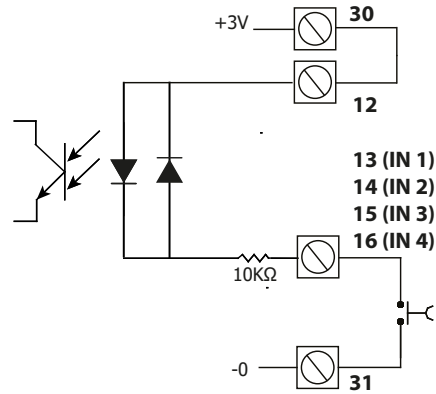

ANALOG INPUTS

4-20mA INPUT

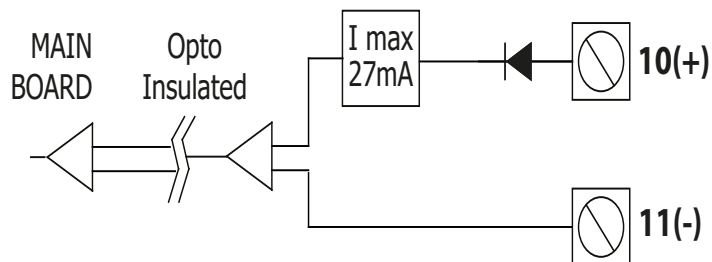

DIGITAL OUTPUTS

Output 4-20mA

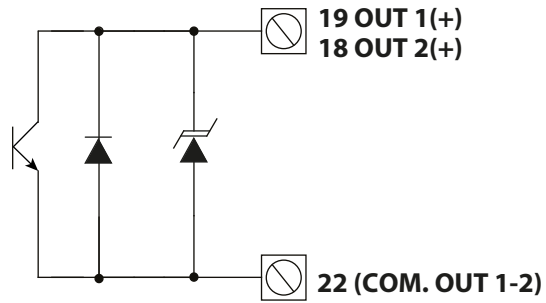

ANALOG OUTPUTS

Output on/off
1250hz

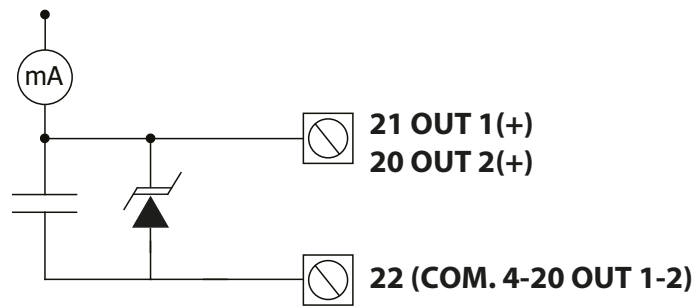

POWER SUPPLIES

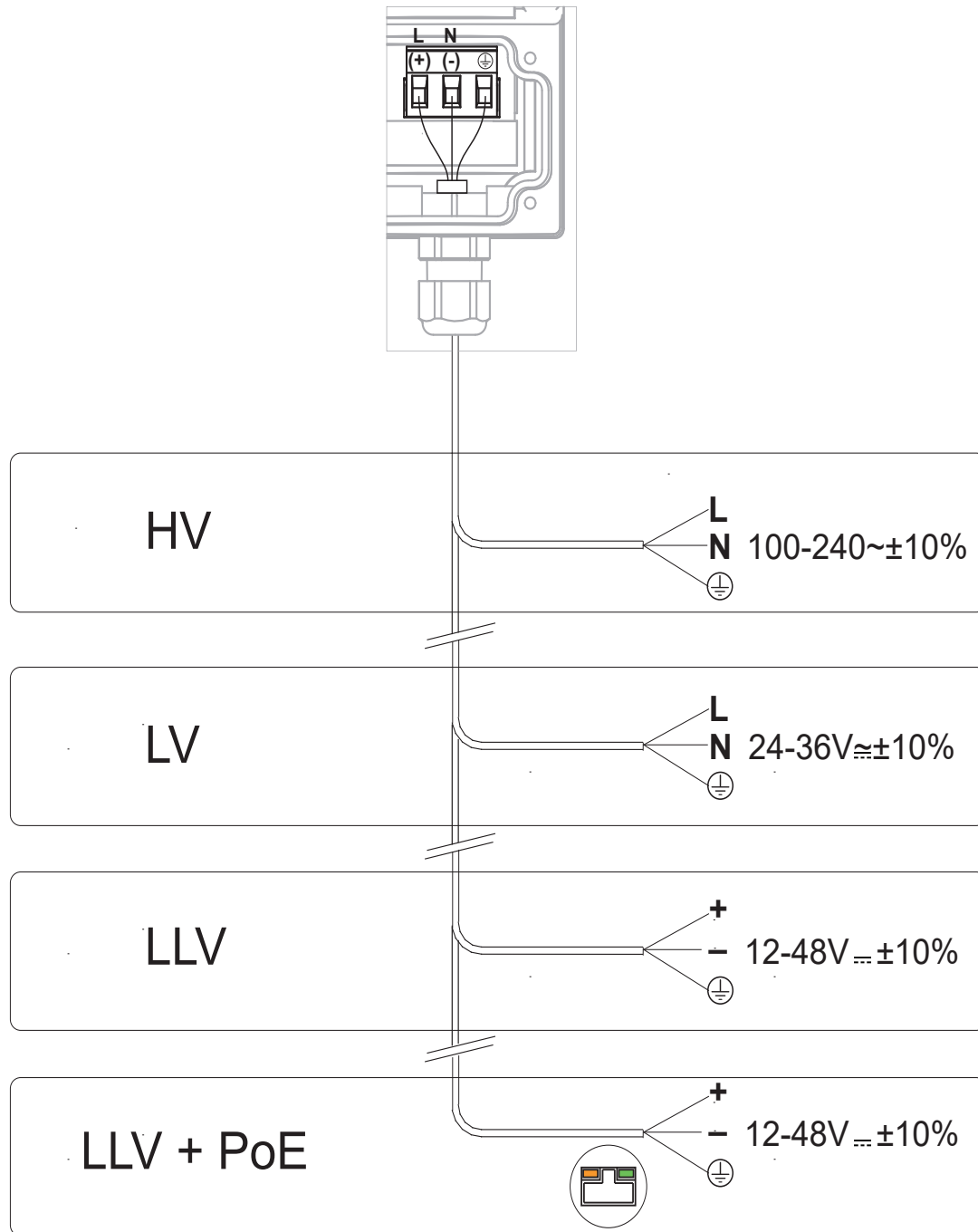

If the PoE power supply version, to guarantee the isolation required by the IEEE for ethernet, the external power supply (optional) must have minimum 1500Vac insulation with respect to earth and to every other connection.

The options above are also available with a rechargeable backup battery.

FUNCTIONS MENU

UNITS

MAIN MENU	
1-Units	
2-Scales	
3-Measure	
4-Alarms	
5-Settings	
6-Factory	
7-Factory	
8-Factory	
9-Factory	
10-Factory	
11-Factory	
12-Factory	
UNITS	
FR.unit	METRIC
Temper. unit	°C
Energy unit	METRIC
Energy unit	(MWh)
D.P. Energy	2
VFv unit	METRIC
VFv unit	(m ³)
VFv D.P.	2
HWv unit	METRIC
HWv unit	(m ³)
HWv D.P.	2
CWv unit	METRIC
CWv unit	(m ³)
CWv D.P.	2
AXi unit	MET.U.
AXi unit	(m ³)
AXi D.P.	2
IP1 unit	METRIC
IP2 unit	METRIC
IP3 unit	METRIC
IP4 unit	MET.U.
OP1 unit	METRIC
OP2 unit	METRIC

- 1.1 Flow rate unit of measure type
- 1.2 Temperature unit of measure
- 1.3 Energy totalizer unit of measure type
- 1.4 Energy totalizer unit of measure
- 1.5 Energy totalizer Decimal point position
- 1.6 VF volume totalizer unit of measure type
- 1.7 VF volume totalizer unit of measure
- 1.8 VF volume total. decimal point position
- 1.9 HW volume totalizer unit of measure type
- 1.10 HW volume totalizer unit of measure
- 1.11 HW volume total. decimal point position
- 1.12 CW volume totalizer unit of measure type
- 1.13 CW volume totalizer unit of measure
- 1.14 CW volume total. decimal point position
- 1.15 AUX input totalizer unit of measure type
- 1.16 AUX input totalizer unit of measure
- 1.17 AUX input total. decimal point position
- 1.18 In Pulse 1 unit of measure type
- 1.19 In Pulse 2 unit of measure type
- 1.20 In Pulse 3 unit of measure type
- 1.21 In Pulse 4 unit of measure type
- 1.22 Out Pulse 1 unit of measure type
- 1.23 Out Pulse 2 unit of measure type

SCALES

MAIN MENU	
1-Units	
2-Scales	
3-Measure	
4-Alarms	
5-Settings	
6-Factory	
7-Factory	
8-Factory	
9-Factory	
10-Factory	
11-Factory	
12-Factory	
SCALES	
FR	m ³ /h,100.00
TPwr	MW,1.0000
Ip11	m ³ ,0.0100
Ip12	m ³ ,0.0100
Ip13	m ³ ,0.0100
Ip14	m ³ ,0.0100
Op11	MWh,10.000
Op12	m ³ ,1.0000
TOP1	(ms)
TOP2	(ms)
Start S.T	(°C)
Full S. T	(°C)
F.S.DTemp	(H)
Prest1	(kPa)
Prest2	(kPa)

- 2.1 Full scale flow rate value
- 2.2 Full scale thermal power value
- 2.3 Channel 1 IN pulse volume value
- 2.4 Channel 2 IN pulse volume value
- 2.5 Channel 3 IN pulse volume value
- 2.6 Channel 4 IN pulse volume value
- 2.7 Channel 1 OUT pulse energy value
- 2.8 Channel 2 OUT pulse volume value
- 2.9 Channel 1 OUT pulse time value
- 2.10 Channel 2 OUT pulse time value
- 2.11 Start scale temperature (Min)
- 2.12 Full scale temperature (Max)
- 2.13 Full scale temperature Delta
- 2.14 Pressure at T1 point
- 2.15 Pressure at T2 point

MEASURES

MAIN MENU		
1-Units		
2-Scales		
3-Measure		
4-Alarms		
5-Inputs		
6-Outputs		
MEASURES		
Sens.Type	PT100	3.1 Temperature sensor type
UFF C.O.	(%)	3.2 Vector fluid flow cut-off threshold
DT Min.	(H)	3.3 Temperature delta cut-off threshold
T1HC enable	OFF	3.4 T1 Heating-Cooling threshold enable
T1HC	(°C)	3.5 T1 Heating-Cooling threshold value
VF Meas. side	T2	3.6 Vector fluid measurement side
VF F.r. src	PLS1	3.7 Vector Fluid flow rate source
Aux Inp. En.	OFF	3.8 Aux nput enable
VF F.r. pls	FRQ	3.9 Vector Fluid f. rate pulse type
Max Tme In1	(s)	3.10 Max Time Period for Input
Max PIs In1	500	3.11 Max Pulses per second for Input
Max PIs In2	500	3.12 Max Pulses per second for Input
Max PIs In3	500	3.13 Max Pulses per second for Input
Max PIs In4	500	3.14 Max Pulses per second for Input
E. Ctrl type	AUT	3.15 Energy counter control type enable
H-Factor	OFF	3.16 Enable Table of Kfactor Coeff.
Subst.type	PPGAPrLSAS201	3.17 Kfactor Substance Type
Subst. Conc. %	---	3.18 Kfactor Substance Concentration
M.Prof.	STD	3.19 Measure acquisition profile
LP S.Freq.	1.0(Hz)	3.20 Low power sampling frequency
LP Cycle sim	OFF	3.21 Low power m.cycle simulation

ALARMS

MAIN MENU		
1-Units		
2-Scales		
3-Measure		
4-Alarms		
5-Inputs		
6-Outputs		
ALARMS		
FM	OFF	4.1 VF Max. flow rate alarm threshold
Fm	OFF	4.2 VF min. flow rate alarm threshold
Pwr M	OFF	4.3 Max. thermal power alarm threshold
Pwr m	OFF	4.4 min. thermal power alarm threshold
DT max	OFF	4.5 Max. temperature delta alarm threshold
DT min	OFF	4.6 Min. temperature delta alarm threshold
T1 Max	OFF	4.7 Max. temperature alarm threshold
T1 min	OFF	4.8 min. temperature alarm threshold
T2 Max	OFF	4.9 Max. temperature alarm threshold
T2 min	OFF	4.10 min. temperature alarm threshold
Hysteresis	(%)	4.11 Hysteresis on alarm thresholds
OC Fault	(mA)	4.12 Out.CurrentAlarm Condition Val.

INPUTS

MAIN MENU		
1-Units		
2-Scales		
3-Measure		
4-Alarms		
5-Inputs		
6-Outputs		
INPUTS		
VFv P. reset	OFF	5.1 Vector fluid vol. part. reset input en.
HWv P. reset	OFF	5.2 Hot water vol. partial reset input en.
CWv P. reset	OFF	5.3 Cold water vol. partial reset input en.
AXi P. reset	OFF	5.4 Aux input partial reset input en.
HEv P. reset	OFF	5.5 Heating energy partial reset input en.
CEv P. reset	OFF	5.6 Cooling energy partial reset input en.
P.Count lock	OFF	5.7 Partial counters lock input enable
VFv T. reset	OFF	5.8 Vector fluid vol. total reset input en.
HWv T. reset	OFF	5.9 Hot water vol. total reset input en.
CWv T. reset	OFF	5.10 Cold water vol. total reset input en.
AXi T. reset	OFF	5.11 Aux input total reset input en.
HEv T. reset	OFF	5.12 Heating energy total reset input en.
CEv T. reset	OFF	5.13 Cooling energy total reset input en.
T.Count lock	OFF	5.14 Total counters lock input enable

OUTPUTS

MAIN MENU	
1-Units	
2-Scales	
3-Measure	
4-Alarms	
5-Inputs	
6-Outputs	
7-Communication	
OUTPUTS	
1.1 D.Out1	T.NRG.PLS
1.2 D.Out2	VF.U.PLS
A.Out1	T. POWER
A.Out2	VF.FLOW
A.Out1	4,0
A.Out2	4,0

6.1	Digital Out 1 function selection
6.2	Digital Out 2 function selection
6.3	Analog Out 1 function selection
6.4	Analog Out 2 function selection
6.5	Analog Out 1 current range sel.
6.6	Analog Out 2 current range sel.

COMMUN.

COMMUNICATION	
BACnet	IP
Modbus	TCP
M-Bus	ON
Dev. Address	1
Com.Speed	9600
Parity	NO 1SB
Ans. Delay	(ms)
ETH DHCP en.	ON
ETH dev IP addr.	010.138.09.
ETH network mask	255.255.25.
ETH gateway addr.	010.138.09.
ETH DNS address	010.138.09.
NTP time server	
Network password	
Net S.En.	ON+OFF
Bnet max mst	127
Bnet ONr	4194302
Bnet ObjName	MV311_Name
Bnet ObjDescr	MV311_desc.
Bnet ObjLoc	MV311_locat.
Bnet pw	Pa55w0rd
Bnet W.E.	OFF
M Bnet Port	47808
MDB_32	AAAA-BBBB
Mbus ID	985000
Mbus Dev.T.	AUTO

7.1	BACnet Communication Protocol
7.2	Modbus Communication Protocol
7.3	MeterBus Communication Protocol
7.4	Device Communication Address
7.5	Communication Speed
7.6	Communication Parity Bits
7.7	Communication Answer Delay
7.8	Ethernet DHCP enable
7.9	Ethernet device IP address
7.10	Ethernet network mask
7.11	Ethernet gateway address
7.12	Ethernet DNS address
7.13	NTP time server name / address
7.14	Network access password
7.15	Network security (SSL-TLS) enable
7.16	BACnet max master
7.17	BACnet Object Instance Number
7.18	BACnet Device Object Name
7.19	BACnet Device Object Description
7.20	BACnet Device Object Location
7.21	BACnet Device Managem. Password
7.22	BACnet Device Object Write Enable
7.23	BACnet Device Ethernet Port number (47808)
7.24	Modbus 32 bits registers order
7.25	MeterBus Identif. number (Secondary add.)
7.26	MeterBus Device Type (media)

6-Outputs	
7-Communication	
8-Display	
9-Data logger	
10-Functions	
11-Diagnostic	
12-System	

DISPLAY

DISPLAY	
Language	EN
Contrast	5
Disp.time	(s)
Disp. F.Num.	0
Disp. P.Lock	OFF
Disp. A.Scr1	0
Disp.date	ALL
LED Op. Mode	SIG
LED VF Blink	ON
LED HW Blink	OFF
LED CW Blink	OFF
LED Comm.Blk	BUS
Quick start	OFF
Web VD En	ON

8.1	Language for all messages
8.2	Display contrast adjustment
8.3	Display/keyboard inactivity time
8.4	Display page function number
8.5	Display lock page number
8.6	Display auto-scroll pages bits (0=disab.)
8.7	Time and date display enable
8.8	LED Operating Mode color switch
8.9	LED Vector Fluid blink enable
8.10	LED Hot Water blink enable
8.11	LED Cold Water blink enable
8.12	LED Communication blink enable
8.13	Quick start menu enable
8.14	Virtual display web interface enable

7-Communication	
8-Display	
9-Data logger	
10-Functions	
11-Diagnostic	
12-System	

DATA LOGGER

DATA LOGGER

D.logger en.	OFF
Meas. units	ON
Header	OFF
Field separat.	;
Decimal separ.	.
Interv.	15
On alarm en.	OFF
Tot. volume	OFF
Par. volume	OFF
Tot. energy	OFF
Par. energy	OFF
Temperatur.	OFF
Therm. power	OFF
V.F. Flow r.	OFF
Log ALARM Nr	OFF
Log TempS D.	OFF
Log Board T.	OFF
Log Int. B. VC	OFF

- 9.1 Data logger sampling enable
- 9.2 Measure units recording enable
- 9.3 Description headers recording enable
- 9.4 Field separator character
- 9.5 Decimal separator character
- 9.6 Sampling interval
- 9.7 Enable recording on alarm change
- 9.8 Enable log of volume total totalizer
- 9.9 Enable log of volume partial totalizer
- 9.10 Enable log of energy total totalizer
- 9.11 Enable log of energy partial totalizer
- 9.12 Enable log of temperatures
- 9.13 Enable log of thermal power
- 9.14 Enable log of vector fluid flow rate
- 9.15 Alarm events number logging enable
- 9.16 Temperature sensor's data logging enable
- 9.17 Board temperatures logging enable
- 9.18 Internal board voltages & curr. log. enable

7-Communication
 8-Display
9-Data logger
 10-Functions
 11-Diagnostic
 12-System

FUNCTIONS

FUNCTIONS

VFv P. reset
HWv P. reset
CWv P. reset
AXi P. reset
HEv P. reset
CEv P. reset
VFv T. reset
HWv T. reset
CWv T. reset
AXi T. reset
HEv T. reset
CEv T. reset
Load Dev. Fact.
Save Dev. Fact.
Acknow.Fact.Warn

- 10.1 Vector fluid vol. part. reset function
- 10.2 Hot water vol. partial reset function
- 10.3 Cold water vol. partial reset function
- 10.4 Aux input partial reset function
- 10.5 Heating energy partial reset function
- 10.6 Cooling energy Partial reset function
- 10.7 Vector fluid vol. total reset function
- 10.8 Hot water vol. total reset function
- 10.9 Cold water vol. total reset function
- 10.10 Aux input total reset function
- 10.11 Heating energy total reset function
- 10.12 Cooling energy total reset function
- 10.13 Load device factory default values
- 10.14 Save device factory default values
- 10.15 Acknowledge factory data warning message

7-Communication
 8-Display
 9-Data logger
10-Functions
 11-Diagnostic
 12-System

DIAGNOSTIC

DIAGNOSTIC

Reboot-Self_Test	
Firmware info	
Quick Setup info	
SD card info	
Battery info	
Disp.sys.values	
Ethernet info.	
F.Bus comm.diag.	
Disp.comm.vars	
Display measures	
S/N	985000
WT	8
BW	0
PT	0
Simulation	OFF

- 11.1 Reboot and execute self test diag. funct.
- 11.2 Firmware version information
- 11.3 Quick Setup information
- 11.4 SD card status information
- 11.5 Battery information
- 11.6 Display diagnostic system values
- 11.7 Ethernet information data
- 11.8 FieldBus comm.diagnostic values
- 11.9 Display comm.diagnostic values
- 11.10 Display internal measured values
- 11.11 Board serial number (read only)
- 11.12 Total working time (read only)
- 11.13 Battery working time (read only)
- 11.14 Partial counters / L.T.S. life time
- 11.15 Flow & Temp. simulation function

9-Data logger
 10-Functions
11-Diagnostic
 12-System

SYSTEM

SYSTEM		
Abit. RTC	ON	12.1 Abilitazione data/ora (Real Time Clock)
Ora Legale	OFF	12.2 Abilitazione ora legale
F. Orario	(h)	12.3 Fuso orario locale
Data/ora	16	12.4 Impostazione data e ora di sistema
Cod. L1	0	12.5 Codice di accesso livello 1
Cod. L2	0	12.6 Codice di accesso livello 2
Cod. L3	0	12.7 Codice di accesso livello 3
Cod. L4	0	12.8 Codice di accesso livello 4
Cod. L5	0	12.9 Codice di accesso livello 5
Cod. L6	0	12.10 Codice di accesso livello 6
Lim. Accesso	OFF	12.11 Limitazione accesso al livello impostato
CT	154472	12.12 Cicli totali di misura
Indirizzo IP Dis	010.011.01.	12.13 Indirizzo IP di rete del dispositivo
Indir. IP Client	010.011.01.	12.14 Indirizzo IP di rete del client
Network mask	255.255.25.	12.15 Network mask
BILANCIAM. T1-T2	(°C)	12.16 Calibrazione bilanciamento temp. T1 - T2
T1 OFFS.	(°C)	12.17 Calibrazione offset temperatura T1
T2 OFFS.	661	12.18 Calibrazione offset temperature T2
ADC 4mA	3327	12.19 Punto di calibrazione 4mA ingresso ADC
ADC 20mA	3453	12.20 Punto di calibrazione 20mA ingresso ADC
DAC1 4mA	14718	12.21 Punto di calibrazione 4mA uscita DAC1
DAC1 20mA	3403	12.22 Punto di calibrazione 20mA uscita DAC1
DAC2 4mA	14637	12.23 Punto di calibrazione 4mA uscita DAC2
DAC2 20mA		12.24 Punto di calibrazione 20mA uscita DAC2
Stand-by		12.25 Attivazione modalita' stand-by (spegnim.)
OS Salva e Bloc.		12.26 Salva e blocca modifica quick setup
FW update		12.27 Aggiornamento firmware

10-Functions
11-Diagnostic
12-System

HOW TO ORDER

Code Example	Code/Description	
0	Certification	
	0	WITHOUT MID-004
	M	CE M CERTIFICATION: MID-004
B	Display	
	A	Blind version (without display)
	B	Graphic display 128 x 48 pixels with back light, 3 keys and RGB status LED.
2	Housing material / Protection rate	
	1	Without Housing
	2	PC/ABS housing sealable
A	Flow Rate Source (Thermal Fluid)	
	A	Pulses
	B	4/20 mA
	C	Pulses - 4/20 mA selectable by the customer, option NOT valid for MID instrument
1	Power supply	
	1	Power Supply : 100 ... 240 VAC 44/66 Hz
	2	Power Supply : 24 ... 36 VAC/VDC 0...44/66 Hz
	3	Power Supply : 12...48 VDC
	4	Power Supply : 12...48 VDC + P.o.E. (Power Over Ethernet - Ethernet port is required)
A	Analogue output	
	A	Without Analog Out
	B	n° 1 Programmable Analogue output 0/4...20/22 mA
	C	n° 2 Programmable Analogue outputs 0/4...20/22 mA
0	Digital Output	
	0	Without Digital Output
	1	With n° 2 Programmable Digital Outputs (Transistor)
A	Communication Gateways & Protocols	
	A	Without Protocol
	B	Ethernet port ONLY (FTPs, WEBs, NTPs, ...)
	C	Modbus RTU (over RS485)
	D	Modbus TCP (over Ethernet)
	E	Modbus RTU + TCP (over RS485 + Ethernet)
	F	Bacnet MS-TP (over RS485)
	G	Bacnet IP (over Ethernet)
	H	BACnet MS-TP + TCP - selectable by the customer - (over RS485 + Ethernet)
	I	BACnet MS-TP + Modbus RTU - selectable by the customer - (over RS485)
	L	Modbus TCP + BACnet IP (over Ethernet)
	M	Modbus RTU + TCP + BACnet MS-TP + IP (over RS485 + Ethernet)
	N	Mbus
	P	Mbus + Modbus IP (over Ethernet)
	Q	Mbus + BACnet IP (over Ethernet)
R	Mbus + Modbus TCP + BACnet IP (over Ethernet)	
Z	Others	

B	Thermal Probe	
	A	Without PT, selectable by the customer (default PT100)
	B	PT 100
	C	PT 500
	D	PT 1000
0	RTC - Measure BackUp - Data Logger	
	0	Without RTC - Measure BackUp - Data Logger
	1	RTC - With Autonomy of 7 days (No measure back-up)
	2	RTC + Measure Back-Up With Autonomy up to 1 Month
	3	RTC - With Autonomy of 7 days + Data Logger with MicroSD Memory 4 GB (No measure back-up)
	4	RTC + Measure BackUp (With Autonomy up to 1 Month)+ Data Logger with MicroSD Memory 4 GB
A	Special Features	
	A	NONE
	B	Connectors IP67 for Ethernet connection (female/female - Valid ONLY for Ethernet Communication Gateway)

Complete code
example for
order



MV311-0B2A1A0A0B0A

ISOIL INDUSTRIA S.p.A.

HEAD OFFICE	SERVICE
Via Fratelli Gracchi, 27 20092 Cinisello Balsamo (MI) Tel +39 02 66027.1 Fax +39 02 6123202 sales@isoil.it	isomagservice@isoil.it

If you want to find the complete list of our distributors access at the following link:
<http://www.isoil.com/en>



Due to the constant technical development and improvement of its products, the manufacturer reserves the right to make changes and/or modify the information contained in this document without notice.