

ASCO™ COIL

SPADE TERMINALS (DIN 46340)

SERIES
ZA34

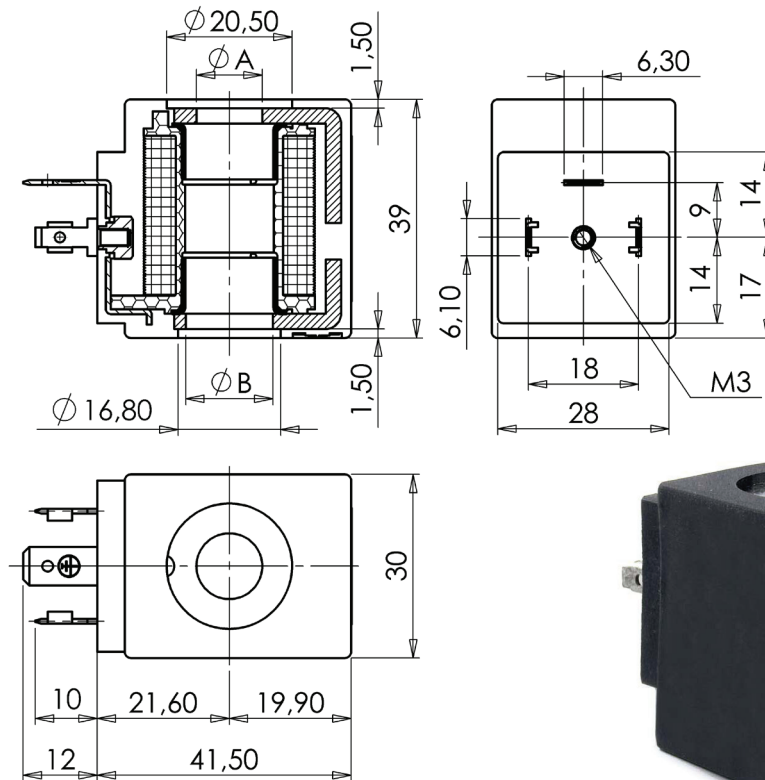

General Features

Complying with 2014/35/EU (LVD) and 2014/30/EU (EMC) directives.

Product in accordance with the RoHS 2 directive.
100% inspected.

Electric Connections

Spade terminals 6,3 x 0,8 (DIN46340), 2 line + 1 earth terminals.
3 poles plug connector (EN175301-803).

Encapsulation Materials

PET (polyethylene terephthalate) fiberglass reinforced (black colour).

Technical Features

| | | |
|---------------------|--------------------------------------|--|
| Continuous duty | ED 100% | |
| Insulation class | H (180°C) | |
| Ambient temperature | -10°C +80°C | |
| Protection degree | IP 65 (EN 60529) with plug connector | |
| Voltages | DC | 12-24V (+10% -5%) |
| | AC | 24V/50Hz - 110V/50Hz (120V/60Hz) |
| | | 230V/50Hz (+10% -15%) (Other voltages and frequencies on request) |

| Type | Power absorption | | | Holes | | Notes | Weight (kg) |
|-------|------------------|---------|--------|-------|------|-------|-------------|
| | AC (VA) | | DC (W) | Ø A | Ø B | | |
| | Inrush | Holding | | | | | |
| ZA34A | 23 | 14 | 9 | 10,7 | 14,2 | 1 | 0,140 |
| ZA34E | - | - | 12 | | | | |

Notes

1 - UL APPROVAL (N° E153691)