



FLOWPULSE SENSOR

Non-invasive clamp-on
flow monitor

**FlowPulse delivers reliable results
across an amazing range of pipe
materials and sizes.**

FlowPulse is a major leap forward in flow measurement, with no need to break into a pipe, reducing the need for expensive installation costs and downtime to the process. The sensor simply clamps to the outside of a pipe and provides reliable, repeatable flow monitoring straight away.

Virtually no installation costs, no interruption to service, clean and simple. FlowPulse is simply fixed in place by a band with a screwdriver. A silicone coupling pad makes sure that the FlowPulse makes good acoustic contact with the pipe.

Technology & Features

FlowPulse uses a novel spread spectrum analysis technique, incorporating new Digital Signal Processing (DSP) that gives exceptional repeatability. The sensor produces a wide ultrasonic beam that is refracted by the pipe wall or reflected by suspended particles in the flowing media.

How Does It Work?

Ultrasound is fired through the pipe wall at 90 degrees to the flow via a tangentially mounted high output ceramic, then refracted at angles across the axis of the flow and subsequently reflected from bubbles, particles, and vortices in all directions and at a wide range of frequencies.

The wide, refracted, ultrasonic beam maximizes the ultrasound energy captured from flowing particles. These



THE RIGHT METER FOR

- Pipe Flow Monitoring
- Influent Pipe Flow
- Process Effluent
- Leachate Pipe Monitoring
- Pump / Process Efficiency & Asset Monitoring

multiple reflections are received back into the unit via a second high-performance ceramic.

Does My Application Need to Be Clean or Dirty Liquid?

Because of the nature of the technology that FlowPulse uses, this sensor works best on applications where there are a lot of bubbles, particles, or vortices. For clean water applications, Pulsar Measurement's Greyline TTFM 6.1 would be best suited. Please see website or product literature for more information.

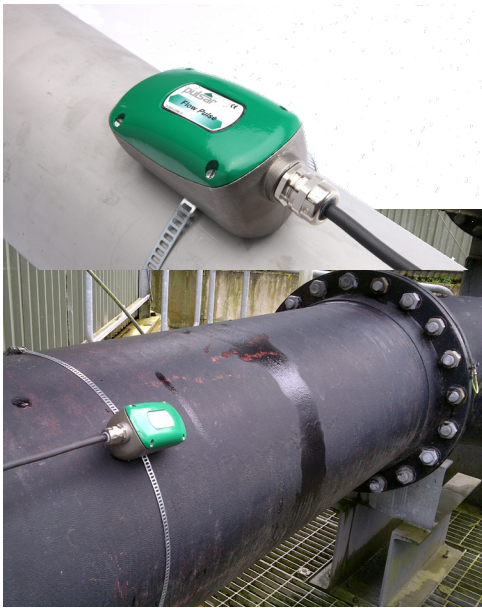

FlowPulse on a real-life application

Returning Signal Analysis

The returned signal is analyzed using FlowPulse’s Refracted Spread Spectrum Analysis (RSSA) digital signal processing platform to derive flow information. RSSA analyzes and integrates the received signals over a wide frequency range, then slices them for real-time analysis and flow rate calculation.

The digital platform also offers robust performance in the repeatability of measurement, as well as the flexibility to adapt to application requirements. For example, features such as damping and response time can be easily customized to suit.

FlowPulse Measurement Range & Pipe Requirements

FlowPulse operates in a flow range from as little as 300 mm/s to 10 m/s (11.8 in/s to 32.8 ft/s), with a minimum particle size of 100 µm and a concentration of 200 ppm or above (the equivalent of hard water).

Pipe material can be rigid plastic, stainless steel, mild steel, or cast iron. Corrugated pipe is not an issue and as long as the silicone pad can fill in the irregularities.

Options & Other Products

FlowPulse operates as a stand-alone device, requiring 18-20 V DC. The sensor includes 1 volt-free programmable relay, provides scalable 4-20mA proportional to flow, and connects to a PC via RS232. A Modbus RTU RS485 output is also provided for third party system integration or connection to Pulsar’s Flow Monitor controller for remote indication and to provide additional outputs.

Optionally, there is also the Flow Monitor for fixed installation and the FlowPulse Handheld Controller for portable measurement requirements. Alternatively, the Greyline DFM 6.1 and Greyline PDFM 6.1 are suitable packages for pipe flow Doppler measurement. Please see the website or product brochures for more details.



FlowPulse Optional Controllers

FlowPulse in a Real-Life Application

There was a need to increase efficiency at a pumping station and it was critical to identify underlying issues in the station infrastructure.

By using Pulsar Measurement’s Quantum 3 pump controller in addition to three FlowPulse sensors, it was possible to configure the controller to show the changing sewage level and flow rate. There were three pumps of similar types installed and the control routine was set up to rotate the duty pump for each cycle. When pump 3 came on duty it was clear that there was a different flow rate - a variation of over 20% compared to the other pumps! Staff had already suspected that there was a problem with a non-return valve and the FlowPulse sensor proved that was indeed the case.

FlowPulse can be used for many different applications, including pump efficiency monitoring either as a stand-alone device or as part of a complete pump control system. Allowing users to add another important dimension to the control of their sites, that of diagnostic flow monitoring.

Technical Specifications

PHYSICAL

Sensor Body Dimensions: 120 mm x 65 mm x 65 mm (4.8 in x 2.6 in x 2.6 in)

Weight: Nominal 1.5 kg (3.3 lb)

Enclosure Material/Description: Type 316 stainless steel casting

Cable Entry Detail: 1 cable entry M20 x 1.5 mm (0.06 in) gland

Maximum Separation: Up to 500 m (1,640 ft)

ENVIRONMENTAL

IP Rating: IP68 (Optional versions of the sensor can be supplied, fitted with factory potted cable)

Max. & Min. Temperature (Electronics): -20 °C to +70 °C (-4 °F to +158 °F)

CE Approval: Listed in the Certificate of Conformity within the manual

PERFORMANCE

Accuracy / Repeatability: ±5% typical subject to installation and pipe conditions

Resolution: 3 mm/s (0.1 in/s)

Velocity Range:

- 300 mm/s to 4 m/s (11.8 in/s to 13.1 ft/s) *standard version* (or)
- 300 mm/s to 10 m/s (11.8 in/s to 32.8 ft/s) *high-flow version*

Response Time: Fully adjustable (1-second minimum)

Minimum Particle Size: >100 µm

Minimum Particle Concentration: >200 ppm

Pipe Diameter:

- V1: 30 mm to 350 mm (1.2 in to 14 in) (or)
- V2: 30 mm to 1.3 m (1.2 in to 4.1 ft) (or)
- V3: up to 2 m (6.6 ft)

Pipe Wall Thickness: Metal or rigid pipe up to 20 mm (0.8 in) thick

Signal Processing: RSSA (Refracted Spread Spectrum Analysis)

OUTPUTS

Analog Output: 4-20mA into a 1 kΩ load (when supply voltage is 22 V DC or greater) with 20 µA resolution and user programmable span.

Digital Output: Full Duplex RS232 to PC Software, Half Duplex RS485 to PC Software, Half Duplex RS485 with Modbus RTU

Volt Free Contacts, Number, and Rating: 1 form "C" (SPDT) rated at 1 A at 24 V DC

PROGRAMMING

PC Programming: Via RS232 or RS485 using Flow Pulse PC

Programmed Data Integrity: Via non-volatile RAM

SUPPLY

Power Supply: 18-28 V DC

Power Consumption: 2.4 W at 24 V typical, 3 W at 24 V maximum

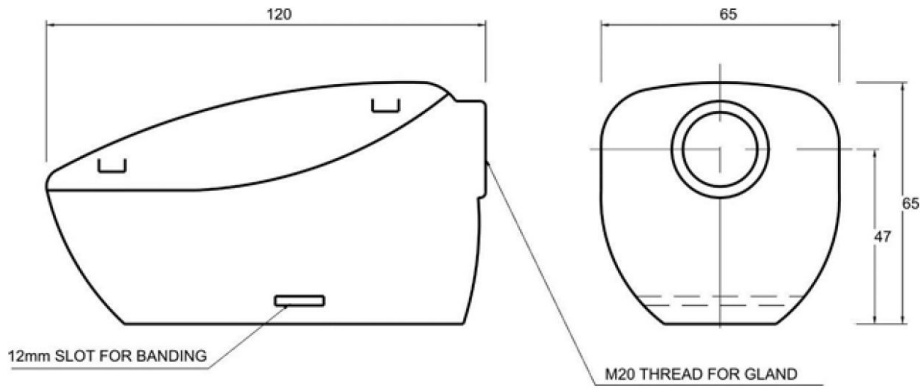

FlowPulse Drawing Side and Back

Delivering the Measure of Possibility

Pulsar Measurement offers worldwide professional support for all of our products, and our network of global partners all offer full support and training. Our facilities in Malvern, UK and Largo, USA are home to technical support teams who are always available to answer your call or attend your site when required. Our global presence, with direct offices in the UK, USA, Canada, and Malaysia, allows us to create close relationships with our customers and provide service, support, training, and information throughout the lifetime of your product.

For more information, please visit our website:

www.pulsarmeasurement.com



INFO@PULSARMEASUREMENT.COM

Pulsar Measurement is a trading name of Pulsar Process Measurement, Ltd.

*Copyright © 2020 Pulsar Measurement
Registered Address: 1 Chamberlain Square CS, Birmingham B3 3AX
Registered No.: 3345604 England & Wales*

United States
+1 888-473-9546

Asia
+60 102 591 332

Canada
+1 855-300-9151

Oceania
+61 428 692 274

United Kingdom
+44 (0) 1684 891371

pulsarmeasurement.com