

## Series PE5



AVENTICS™ Series PE5





























## Pressure sensor, Series PE5

- Operating pressure -1 ... 0 -1 ... 1 0 ... 6 0 ... 10 0 ... 12 -1 ... 10 bar
- electronic
- Output signal analog 0 - 10 V DC, 4 - 20 mA
- Output signal digital 2 x PNP, NPN, Push-pull PNP, NPN, Push-pull PNP, NPN, push-pull, 1x IO-Link 2x PNP, NPN, push-pull in standard mode, 1x in leakage mode
- Electr. connection Plug M12x1 4-pin Plug M12x1 5-pin
- Compressed air connection Internal thread G 1/4 push-in fitting Ø 4



Type	electronic
Certificates	CE declaration of conformity, cULus, RoHS, Conforms with REACH, Free of substances that impair surface wetting in the coating process
Ambient temperature min./max.	0 ... 60 °C
Medium temperature min./max.	0 ... 60 °C
Medium	Compressed air (max. 40 µm)
Max. oil content of compressed air	40 mg/m <sup>3</sup>
Measurement	Relative pressure
Display	LCD display, 4 digits, Color setting: green or red
Units displayed	bar psi kPa MPa inHg
Switching logic	NO/NC (adjustable)
Shock resistance max.	30 g
Vibration resistance	5 g (10 - 150 Hz)
Precision (% of full scale value)	±1.5% in temperature range of 10 - 30°C ± 2 % including temperature drift
Repeatability (% of full scale value)	± 0,2 %
Switching time	5 ms
Switching point	adjustable 0 ... 100%
Resetting point	adjustable 0 ... 100%
Hysteresis	adjustable
Delayed hysteresis	adjustable
Window function	adjustable
DC operating voltage min./max.	17 ... 30 V DC
Analog output	0 - 10 V DC, 4 - 20 mA
Quiescent current consumption	40 mA
Analog output linearity	± 0.5% of the final value
Maximum load (analog current output)	600 Ω
Short circuit resistance	Max. 600 ohms (current output) Min. 3K ohms (voltage output)
Mounting types	Directly on hat rail and wall mounting For panel installation using mounting kit via double nipple
Protection class	IP65 IP67 with connections assembled
Weight	0.04 kg

## Technical data

Part No.		Operating pressure range	Protection against overpressure
		min./max.	
R412010761		-1 ... 0 bar	5 bar
R412010760		-1 ... 0 bar	5 bar
R412010769		-1 ... 0 bar	5 bar
R412010768		-1 ... 0 bar	5 bar
R412010775		-1 ... 0 bar	5 bar
R412010774		-1 ... 0 bar	5 bar
R412010763		-1 ... 1 bar	5 bar
R412010762		-1 ... 1 bar	5 bar
R412010771		0 ... 6 bar	15 bar
R412010770		0 ... 6 bar	15 bar
R412010765		0 ... 6 bar	15 bar
R412010764		0 ... 6 bar	15 bar
R412010777		0 ... 6 bar	15 bar
R412010776		0 ... 6 bar	15 bar
R412010773		0 ... 10 bar	15 bar
R412010772		0 ... 10 bar	15 bar
R412010767		0 ... 10 bar	15 bar
R412010766		0 ... 10 bar	15 bar
R412010779		0 ... 10 bar	15 bar
R412010778		0 ... 10 bar	15 bar
R412010782		0 ... 12 bar	16 bar
R412010781		0 ... 12 bar	16 bar
R412010806		0 ... 12 bar	16 bar
R412010805		0 ... 12 bar	16 bar
R412026774		-1 ... 10 bar	15 bar

Part No.	Output signal
	Analog
R412010761	-
R412010760	-
R412010769	0 - 10 V DC-4 ... 20 mA
R412010768	0 - 10 V DC-4 ... 20 mA
R412010775	-
R412010774	-
R412010763	-
R412010762	-
R412010771	0 - 10 V DC-4 ... 20 mA
R412010770	0 - 10 V DC-4 ... 20 mA
R412010765	-
R412010764	-
R412010777	-
R412010776	-
R412010773	0 - 10 V DC-4 ... 20 mA
R412010772	0 - 10 V DC-4 ... 20 mA
R412010767	-
R412010766	-

Part No.	Output signal
	Analog
R412010779	-
R412010778	-
R412010782	-
R412010781	-
R412010806	-
R412010805	-
R412026774	0 - 10 V DC-4 ... 20 mA

Part No.	Output signal	Input signal
	digital	digital
R412010761	2 x PNP, NPN, Push-pull	-
R412010760	2 x PNP, NPN, Push-pull	-
R412010769	PNP, NPN, Push-pull	-
R412010768	PNP, NPN, Push-pull	-
R412010775	PNP, NPN, push-pull, 1x IO-Link	-
R412010774	PNP, NPN, push-pull, 1x IO-Link	-
R412010763	2 x PNP, NPN, Push-pull	-
R412010762	2 x PNP, NPN, Push-pull	-
R412010771	PNP, NPN, Push-pull	-
R412010770	PNP, NPN, Push-pull	-
R412010765	2 x PNP, NPN, Push-pull	-
R412010764	2 x PNP, NPN, Push-pull	-
R412010777	PNP, NPN, push-pull, 1x IO-Link	-
R412010776	PNP, NPN, push-pull, 1x IO-Link	-
R412010773	PNP, NPN, Push-pull	-
R412010772	PNP, NPN, Push-pull	-
R412010767	2 x PNP, NPN, Push-pull	-
R412010766	2 x PNP, NPN, Push-pull	-
R412010779	PNP, NPN, push-pull, 1x IO-Link	-
R412010778	PNP, NPN, push-pull, 1x IO-Link	-
R412010782	2 x PNP, NPN, Push-pull	-
R412010781	2 x PNP, NPN, Push-pull	-
R412010806	PNP, NPN, push-pull, 1x IO-Link	-
R412010805	PNP, NPN, push-pull, 1x IO-Link	-
R412026774	2x PNP, NPN, push-pull in standard mode, 1x in leakage mode	1 x PNP

Part No.	electrical connections	Compressed air connection	Fig.	
R412010761	Plug, M12x1, 4-pin	Internal thread, G 1/4	Fig. 1	-
R412010760	Plug, M12x1, 4-pin	push-in fitting, Ø 4	Fig. 2	-
R412010769	Plug, M12x1, 4-pin	Internal thread, G 1/4	Fig. 1	-
R412010768	Plug, M12x1, 4-pin	push-in fitting, Ø 4	Fig. 2	-
R412010775	Plug, M12x1, 4-pin	Internal thread, G 1/4	Fig. 1	1)
R412010774	Plug, M12x1, 4-pin	push-in fitting, Ø 4	Fig. 2	1)
R412010763	Plug, M12x1, 4-pin	Internal thread, G 1/4	Fig. 1	-
R412010762	Plug, M12x1, 4-pin	push-in fitting, Ø 4	Fig. 2	-
R412010771	Plug, M12x1, 4-pin	Internal thread, G 1/4	Fig. 1	-
R412010770	Plug, M12x1, 4-pin	push-in fitting, Ø 4	Fig. 2	-
R412010765	Plug, M12x1, 4-pin	Internal thread, G 1/4	Fig. 1	-

Part No.	electrical connections	Compressed air connection	Fig.	
R412010764	Plug, M12x1, 4-pin	push-in fitting, Ø 4	Fig. 2	-
R412010777	Plug, M12x1, 4-pin	Internal thread, G 1/4	Fig. 1	1)
R412010776	Plug, M12x1, 4-pin	push-in fitting, Ø 4	Fig. 2	1)
R412010773	Plug, M12x1, 4-pin	Internal thread, G 1/4	Fig. 1	-
R412010772	Plug, M12x1, 4-pin	push-in fitting, Ø 4	Fig. 2	-
R412010767	Plug, M12x1, 4-pin	Internal thread, G 1/4	Fig. 1	-
R412010766	Plug, M12x1, 4-pin	push-in fitting, Ø 4	Fig. 2	-
R412010779	Plug, M12x1, 4-pin	Internal thread, G 1/4	Fig. 1	1)
R412010778	Plug, M12x1, 4-pin	push-in fitting, Ø 4	Fig. 2	1)
R412010782	Plug, M12x1, 4-pin	Internal thread, G 1/4	Fig. 1	-
R412010781	Plug, M12x1, 4-pin	push-in fitting, Ø 4	Fig. 2	-
R412010806	Plug, M12x1, 4-pin	Internal thread, G 1/4	Fig. 1	1)
R412010805	Plug, M12x1, 4-pin	push-in fitting, Ø 4	Fig. 2	1)
R412026774	Plug, M12x1, 5-pin	Internal thread, G 1/4	Fig. 3	2)

1) The IO-Link device description (IODD) for the PE5 pressure sensor is available for download in the Media Centre.

2) Suitable for leak tests

## Technical information

Alternative pressure connection (G1/4) on the rear side (closed with plug)  
Display color selectable, red or green

## Technical information

Material	
Housing	Polycarbonate
Seals	Acrylonitrile butadiene rubber
Blanking plug	Polyoxymethylene
Electr. connection	Aluminum, black anodized

## Dimensions

Fig. 1

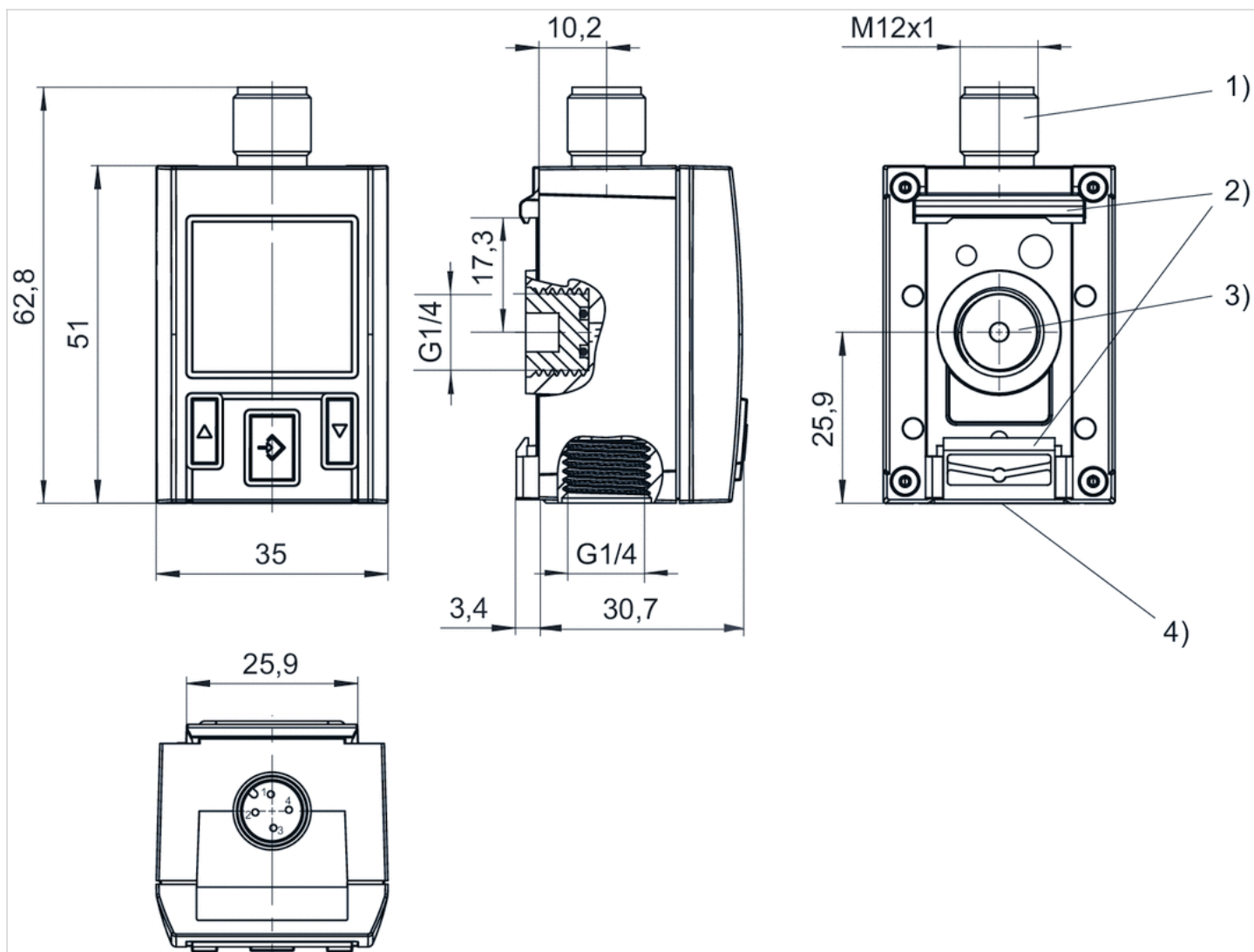

- 1) M12x1 electrical connection
- 2) Mounting for hat rail and wall mounting
- 3) Alternative pressure connection (G1/4) closed with plug
- 4) Pressure connection G1/4

Fig. 2

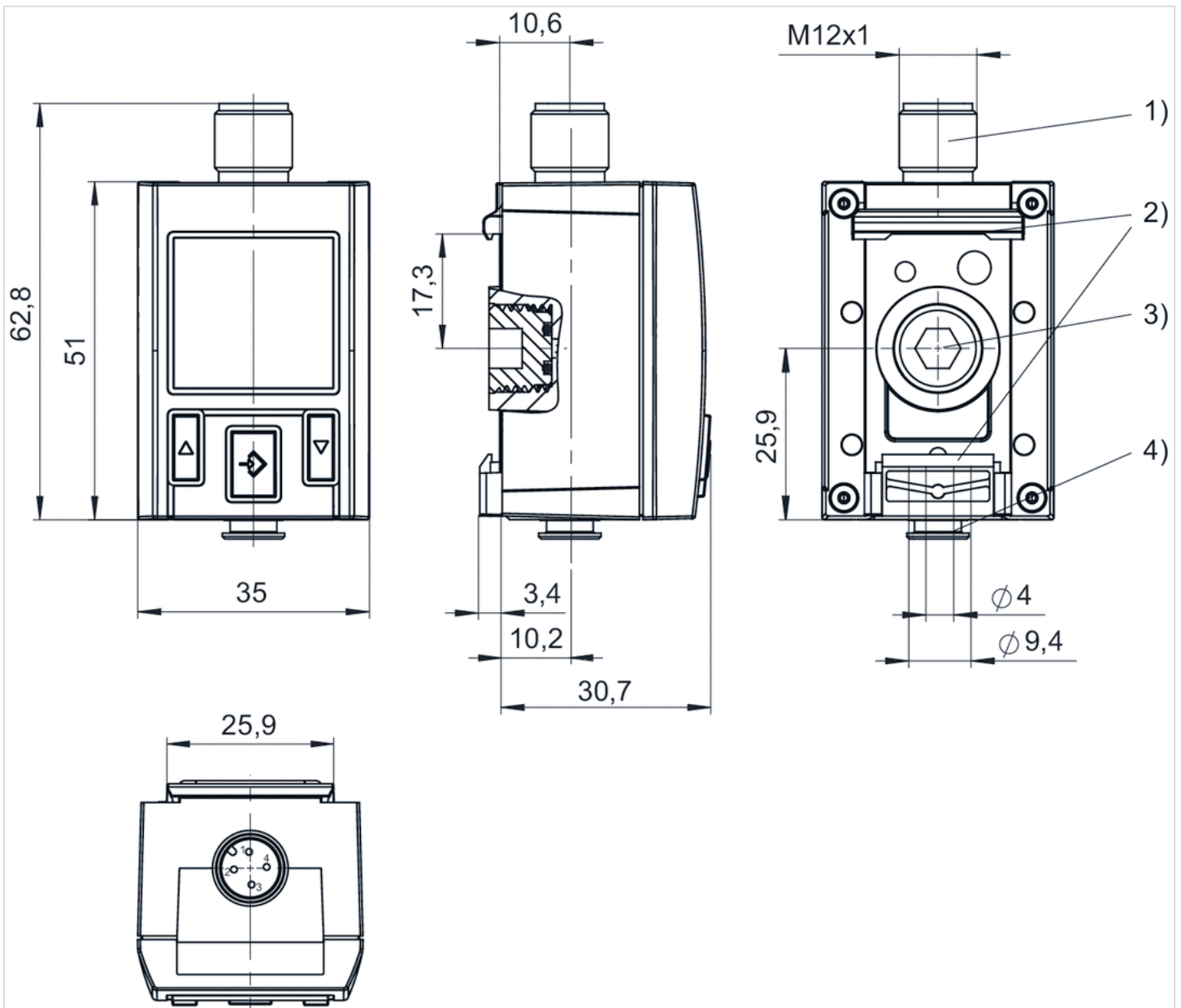

- 1) M12x1 electrical connection
- 2) Mounting for hat rail and wall mounting
- 3) Alternative pressure connection (G1/4) closed with plug
- 4) Pressure connection, tubing Ø 4 mm

Fig. 3, Electr. connection for leak test

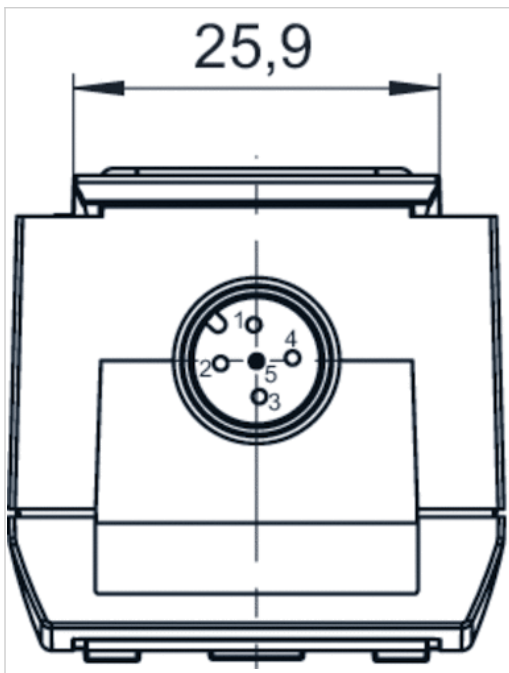

Display and operation area

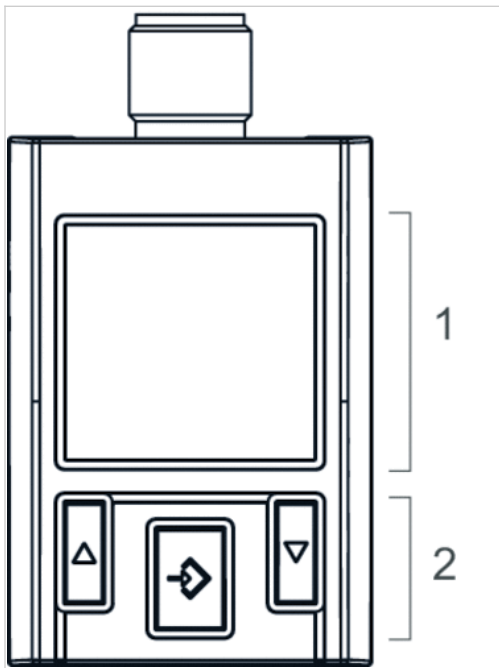

- 1) LCD display
- 2) Control panel with 3 buttons



## Diagrams

### Operating mode, PNP

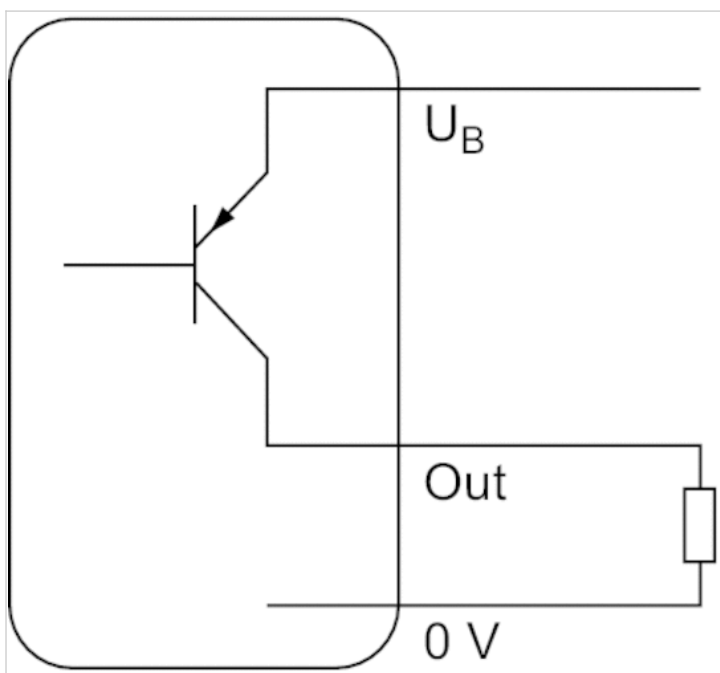

### Operating mode, NPN

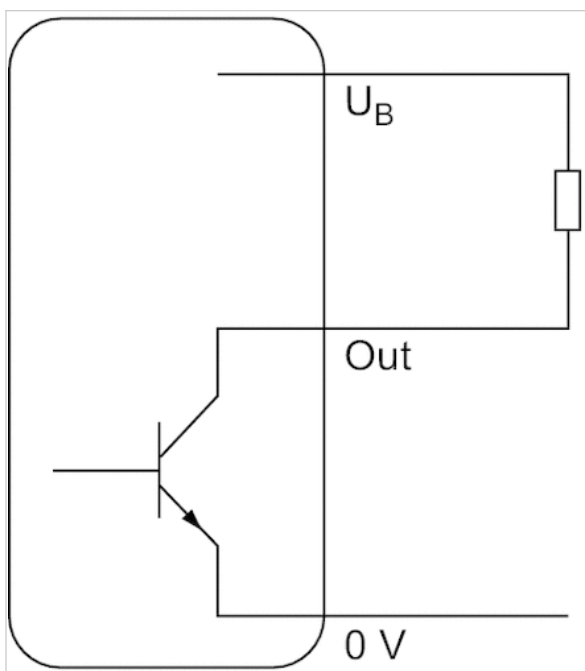

## Operating mode, Push-pull

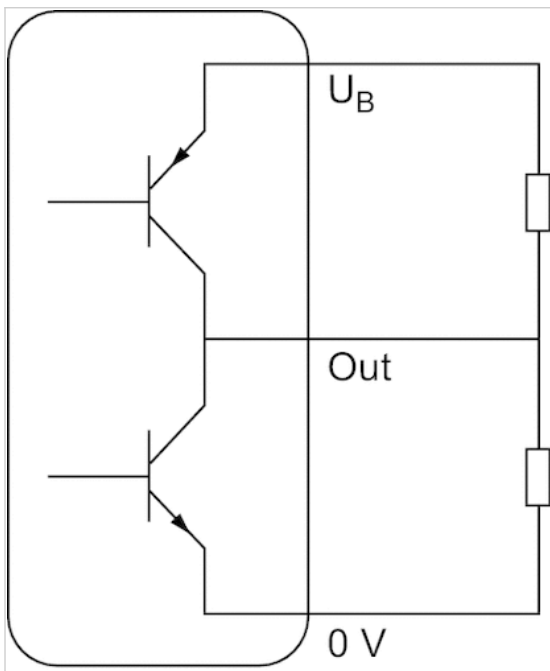

Hysteresis function: switching and resetting behavior dependent on pressure  $p$  and time  $t$ , in case of overpressure

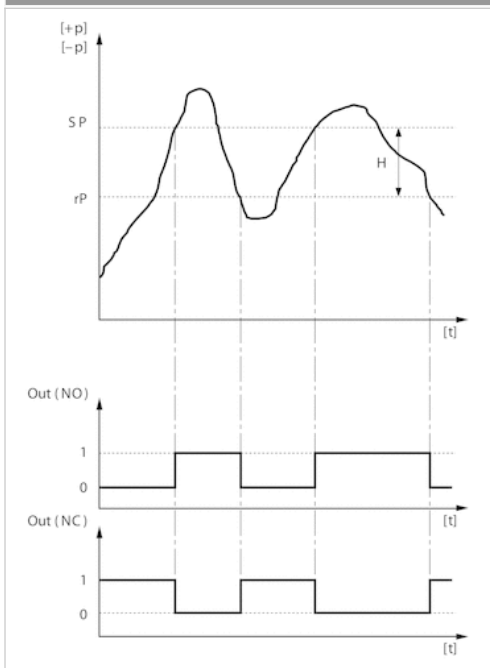

H: Hysteresis

SP = switching point

RP = resetting point

Out (NC): switch output, break contact

Out (NO): switch output, make contact

Hysteresis function: switching and resetting behavior dependent on pressure  $p$  and time  $t$ , in case of underpressure

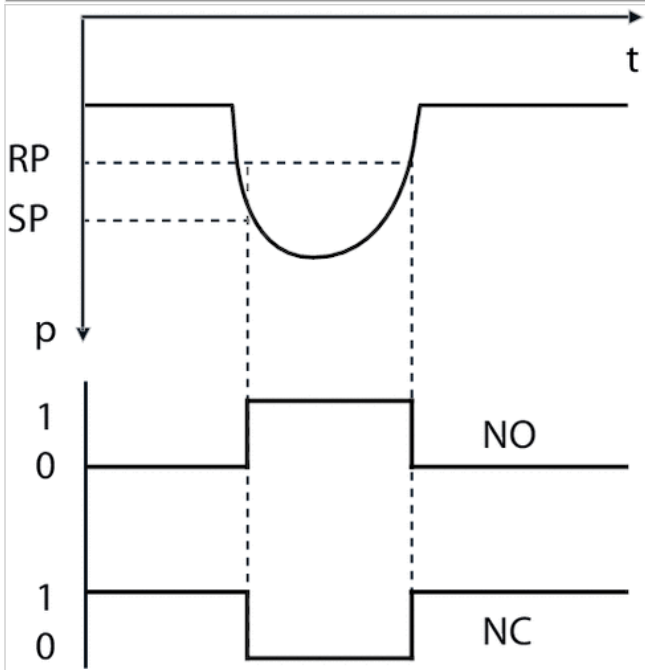

Delayed hysteresis function: switching and resetting behavior depending on pressure  $p$  and time  $t$

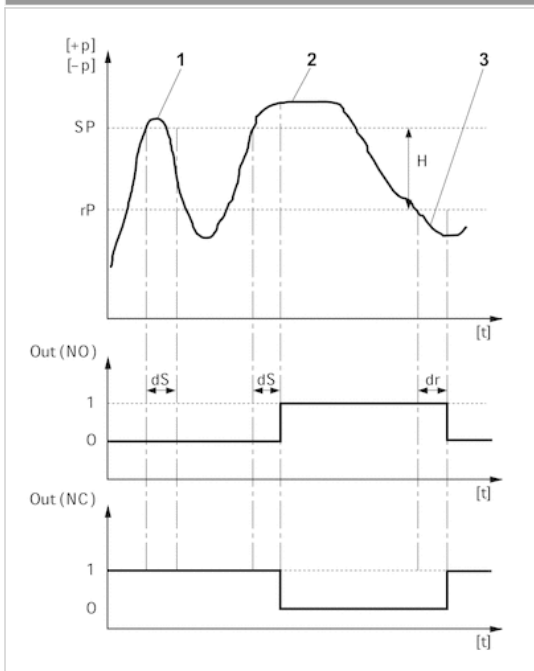

H: Hysteresis

SP = switching point

RP = resetting point

Out (NC): switch output, break contact

Out (NO): switch output, make contact

dS: switching delay

dR = reset delay

1) period of pressure over the switching point  $dS$ : pressure sensor does not switch

2) Period of pressure over the switching point  $> dS$ : pressure sensor switches

3) Period of pressure under the resetting point  $> dR$ : pressure sensor switches

Window function: switching and resetting behavior depending on pressure p and time t

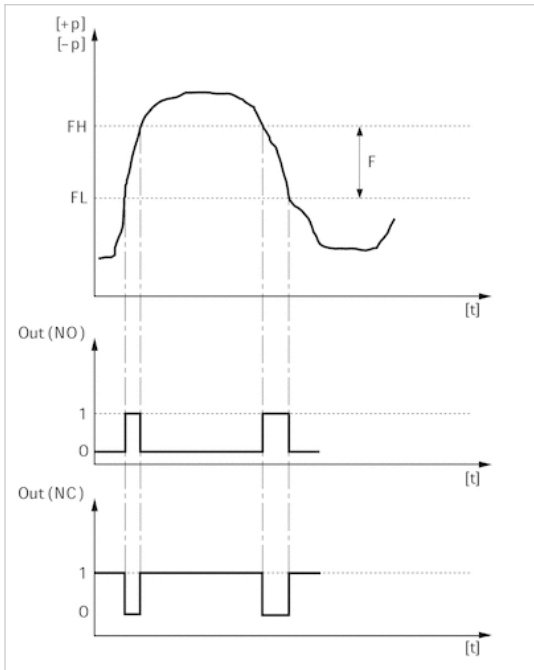

FH: pressure band, upper value  
 FL: pressure band, lower value  
 Out (NC): switch output, break contact  
 Out (NO): switch output, make contact

Leakage characteristic

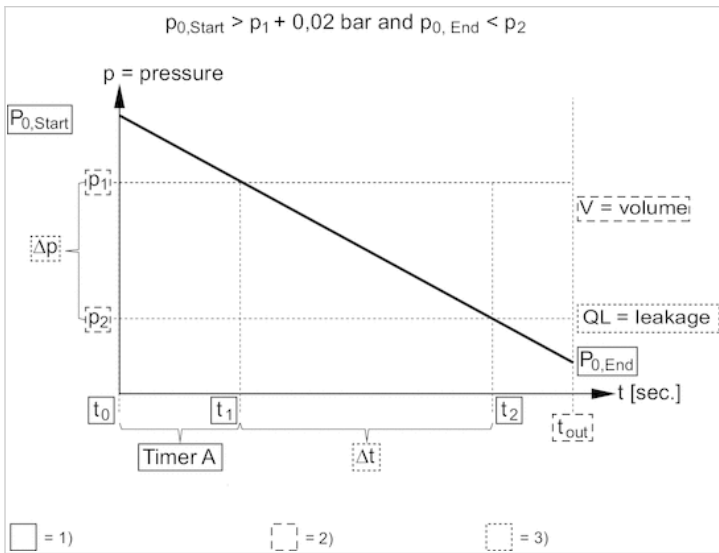

- 1) Internally stored parameter
- 2) Adjustable parameter
- 3) Output value

Circuit diagram

Block diagram, 1x PNP and 1x analog

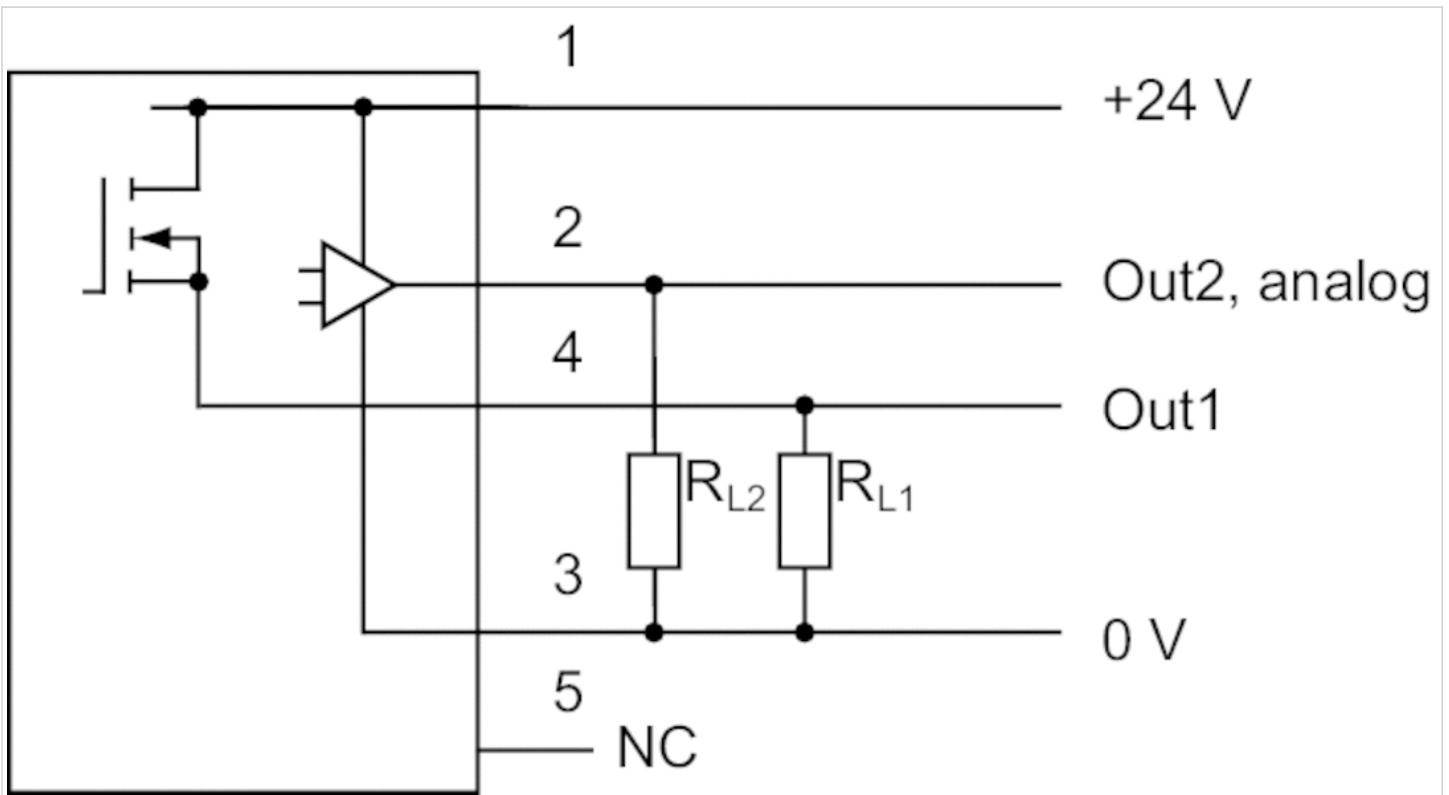

RL = storable position

Block diagram, 1x NPN and 1x analog

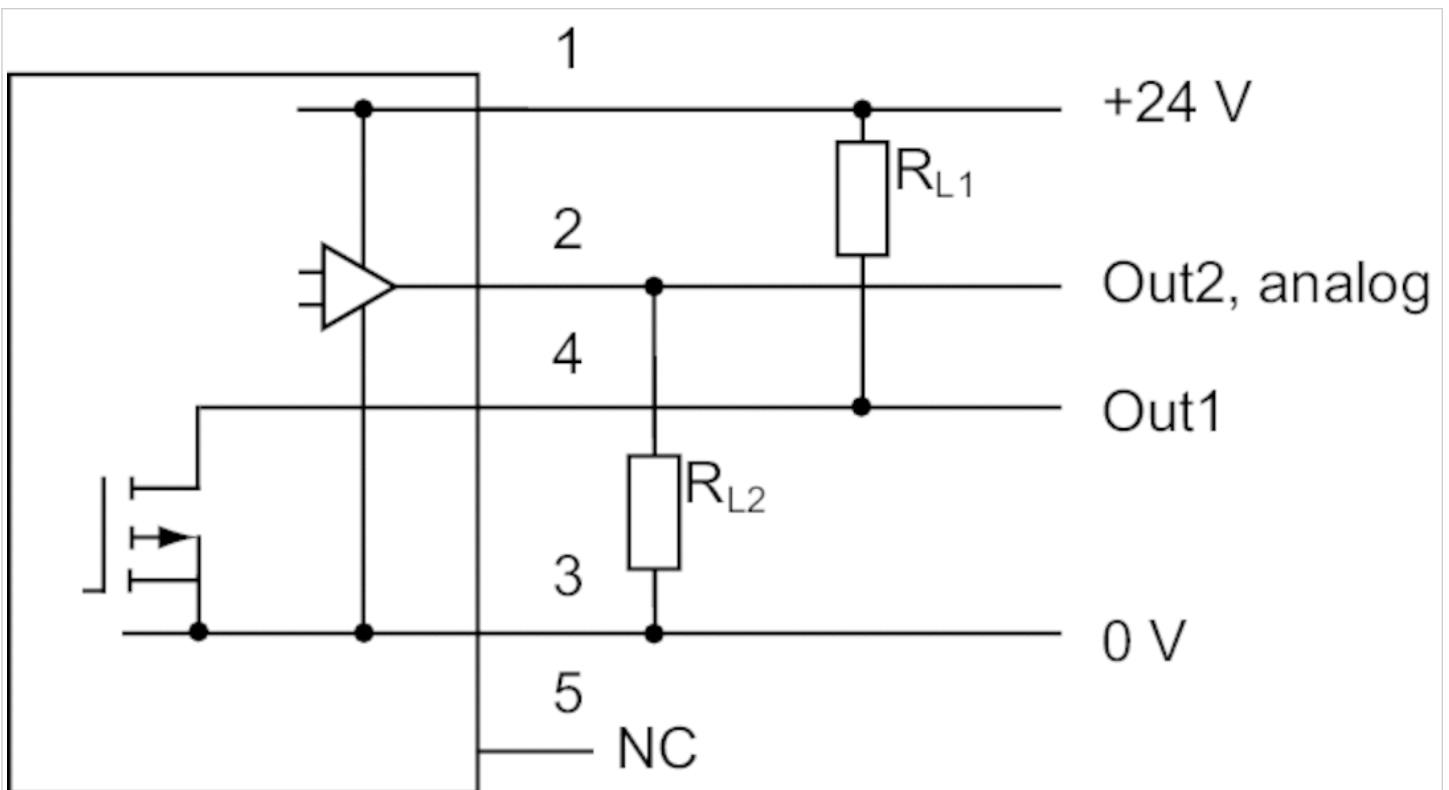

RL = storable position

## Pin assignments

### Pin assignments, M12x1, 4-pin

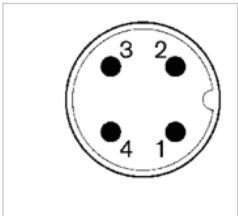

Pin	1	
Allocation	operational voltage + UB	
	2	3
switch output Out2, analog: A or V, digital: PNP, NPN, push-pull		0 V
	4	
switch output Out1, digital: PNP, NPN, push-pull		

## Pin assignments

### Pin assignments, M12x1, 5-pin

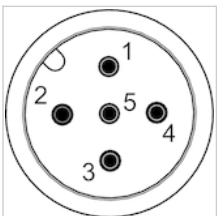

Pin	1	2	3
Allocation	Supply Voltage	Switch output PNP/NPN/push-pull, switchable	0 V
	4		
Switch output PNP/NPN/push-pull/leakage mode, digital switch input PNP			
	5		
Analog output ( 0 to 10 V DC, 4 to 20 mA)			

# Double nipple, Series PE5

- External thread



Weight per piece

0.04 kg

## Technical data

Part No.	Port G	Port D	Delivery unit
R412010015	G 1/4	G 1/8	2 piece
R412010016	G 1/4	G 1/4	2 piece

## Dimensions

### Dimensions

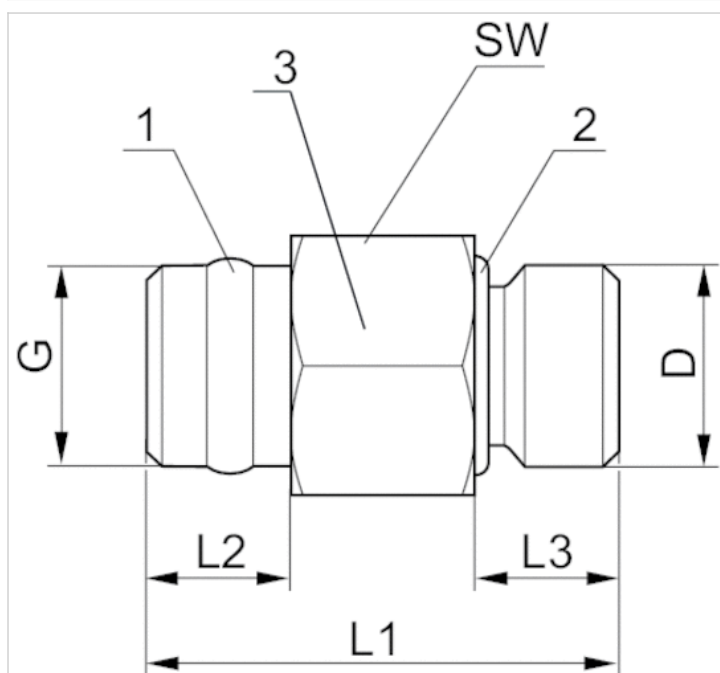

- 1) sealing ring Polytetrafluorethylen
- 2) O-ring - acrylonitrile butadiene rubber
- 3) Housing - brass, nickel-plated

## Dimensions

Part No.	Port G	Port D	L1	L2	L3	SW
R412010015	G 1/4	G 1/8	30	10	8.5	17
R412010016	G 1/4	G 1/4	30	10	8.5	17



# Round plug connector, Series CON-RD

- Socket M12x1 5-pin A-coded angled 90°
- open cable ends
- for DeviceNet
- with cable
- unshielded



Ambient temperature min./max.	-40 ... 85 °C
Operational voltage	48 V AC/DC
Protection class	IP65
Wire cross-section	0.34 mm <sup>2</sup>
Weight	See table below

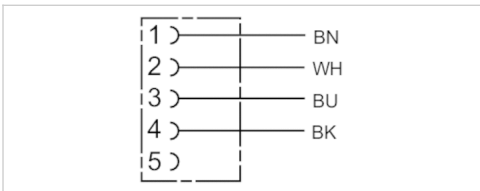

## Technical data

Part No.	Max. current	Number of wires	Cable-Ø	Cable length	Weight
1834484259	4 A	4	5.2 mm	3 m	0.126 kg
1834484260	4 A	4	5.2 mm	5 m	0.195 kg
1834484261	4 A	4	5.2 mm	10 m	0.38 kg

## Technical information

The specified protection class is only valid in assembled and tested state.

## Technical information

Material	
Cable sheath	Polyurethane

## Dimensions

### Dimensions

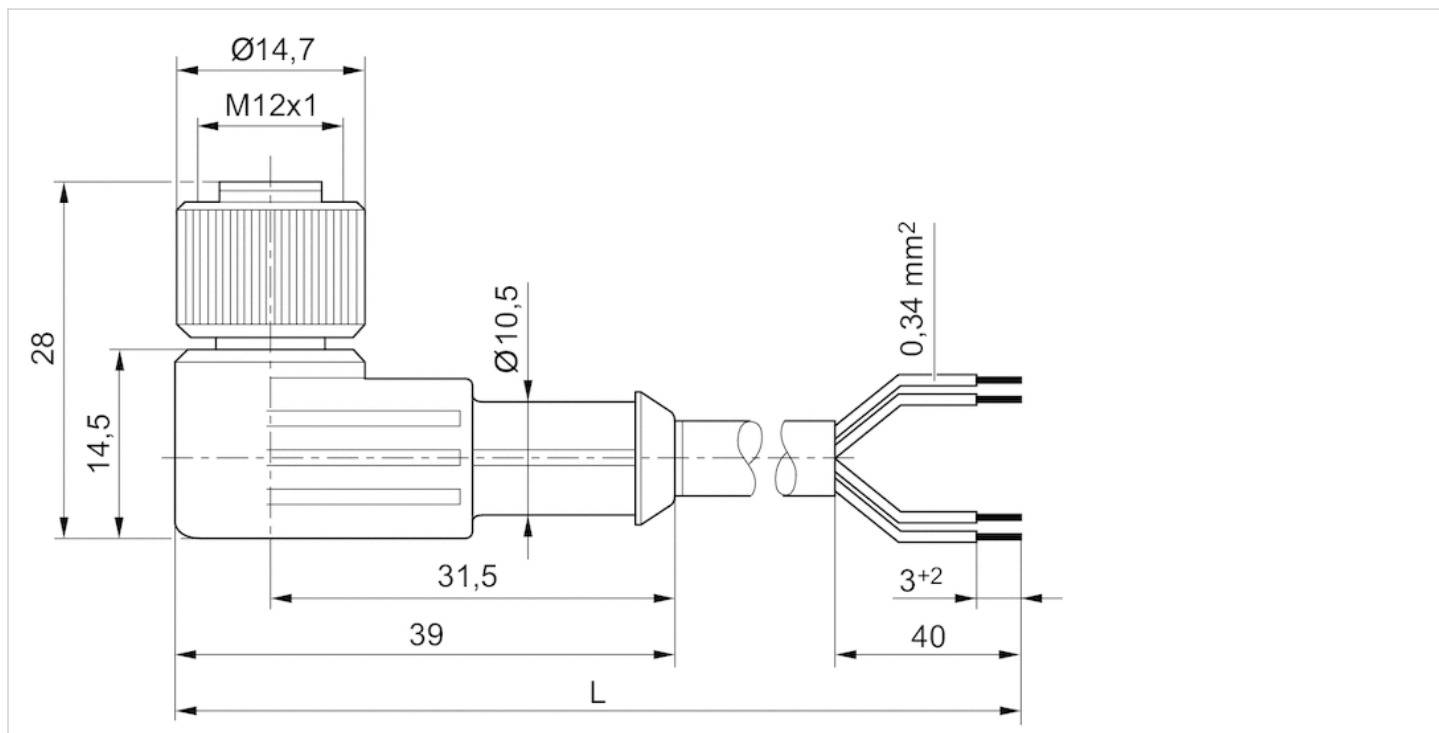

L = length

## Pin assignments

### Pin assignment, socket

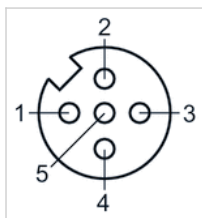

- (1) BN=brown
- (2) WH=white
- (3) BU=blue
- (4) BK=black
- (5) not assigned

# Round plug connector, Series CON-RD

- Socket M12x1 5-pin A-coded angled 90°
- open cable ends
- with cable
- shielded



Ambient temperature min./max.	-25 ... 80 °C
Operational voltage	48 V AC/DC
Protection class	IP67
Wire cross-section	0.34 mm <sup>2</sup>
Weight	See table below

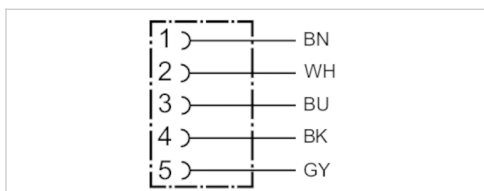

## Technical data

Part No.	Max. current	Number of wires	Cable-Ø	Cable length	Weight
R419800109	4 A	5	6 mm	2.5 m	0.145 kg
R419800110	4 A	5	6 mm	5 m	0.27 kg
R419800546	4 A	5	6 mm	10 m	0.514 kg

## Technical information

Material	
Housing	Thermoplastic elastomer
Cable sheath	Polyurethane

## Dimensions

### Dimensions

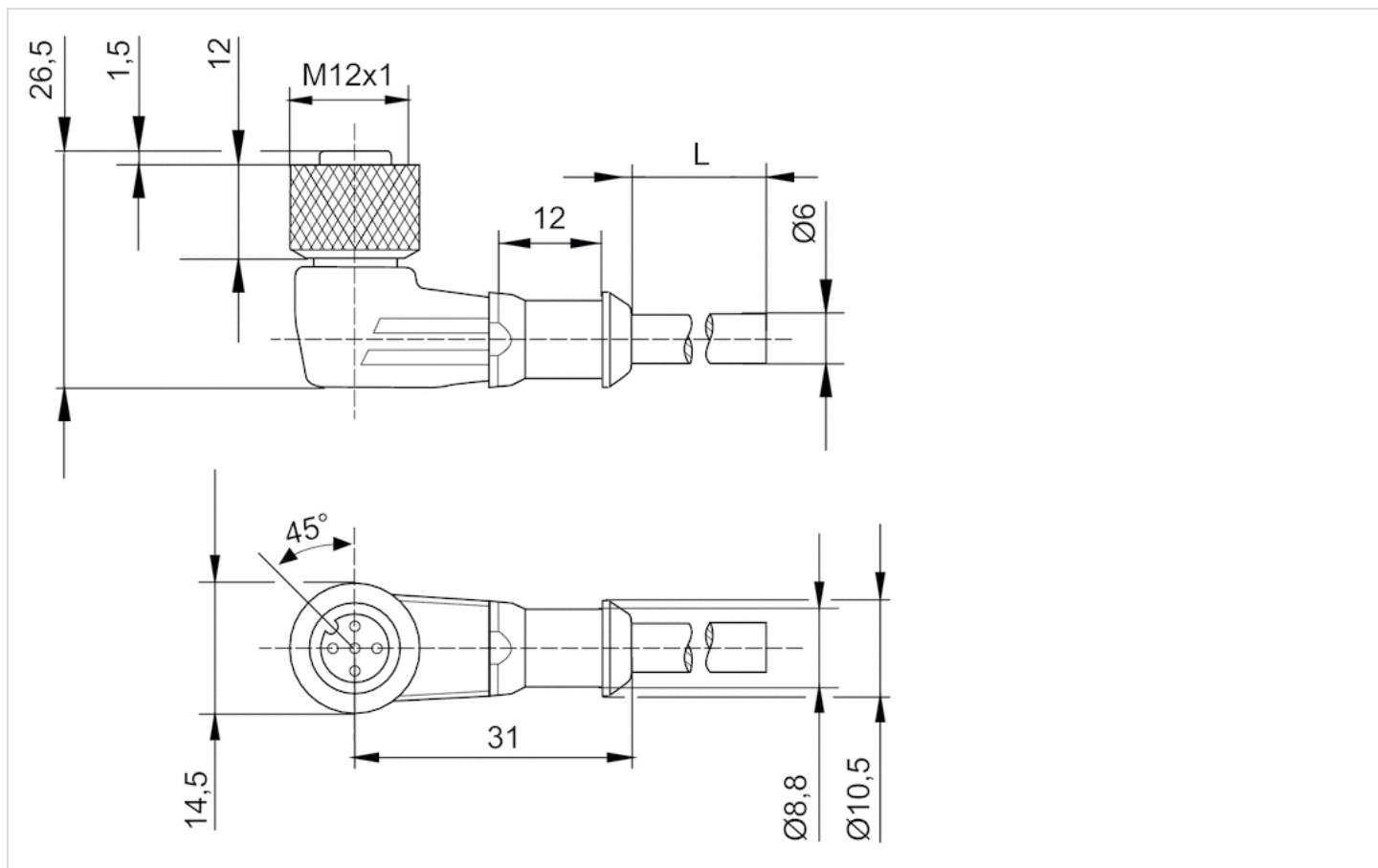

L = length

## Pin assignments

### Pin assignment, socket

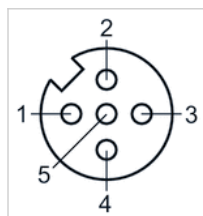

- (1) BN=brown
- (2) WH=white
- (3) BU=blue
- (4) BK=black
- (5) GY=grey

# Double nipple

- External thread
- G 1/4
- External thread
- G 1/8 G 1/4
- FPT-S-RDO



Working pressure min./max.

0 ... 16 bar

Ambient temperature min./max.

-20 ... 80 °C

## Technical data

Part No.	Port G	Port D	Delivery unit
1823391016	G 1/4	G 1/8	10 piece
1823391017	G 1/4	G 1/4	10 piece

## Technical information

Material	
Material	Brass, nickel-plated
Seal	Polyvinyl chloride, hard

## Dimensions

### Dimensions

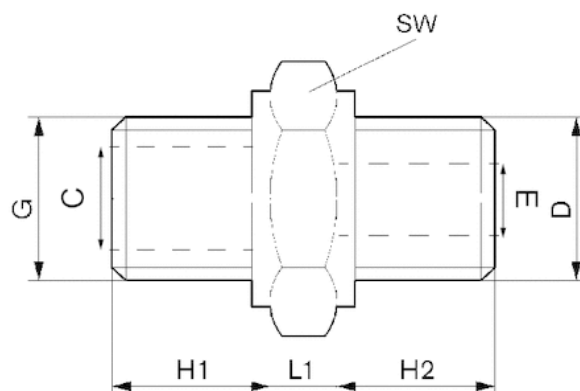

## Dimensions

Part No.	Port D	Port G	ØC	ØE	H1	H2	L1	SW
1823391016	G 1/8	G 1/4	8	5	10	7	5	17
1823391017	G 1/4	G 1/4	8	7.5	10	10	5	17

# Wall mounting and hat rail

- for PE5



Weight

0.004 kg

## Technical data

Part No.	Delivery unit
R412010405	1 piece

Screws included in scope of delivery: 2 x M5x20, DIN EN ISO 4762

## Technical information

Material	
Housing	Polyamide

## Dimensions

### Dimensions

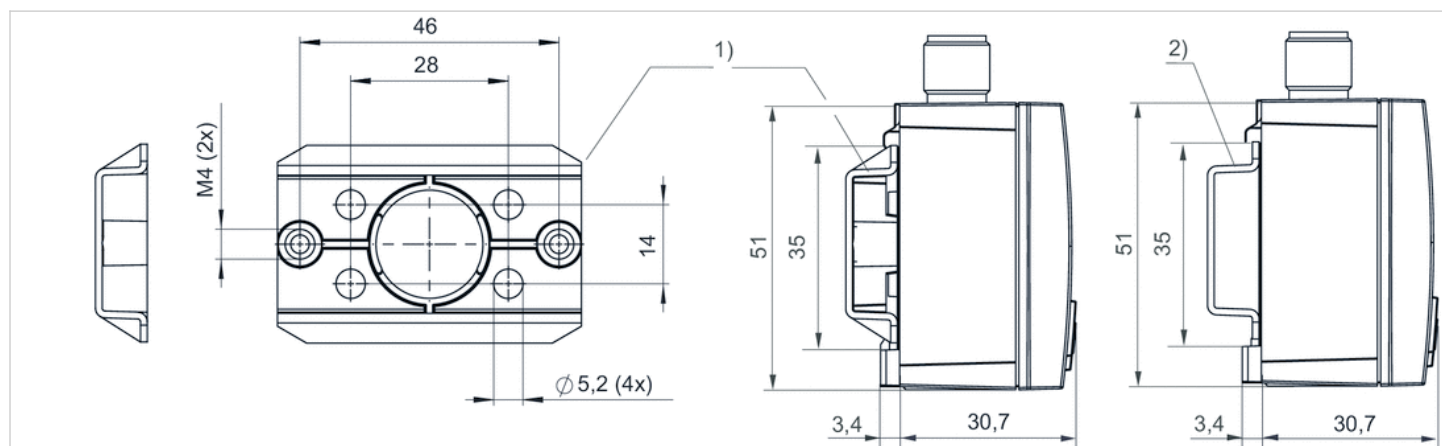

1) Wall mounting

2) DIN rail

# Control panel installation kit

- for PE5



Ambient temperature min./max.

0 ... 60 °C

## Technical data

Part No.	Delivery unit
R412010406	1 piece

## Technical information

Material	
Housing	Acrylonitrile butadiene styrene
Seal	Polyurethane



## Dimensions

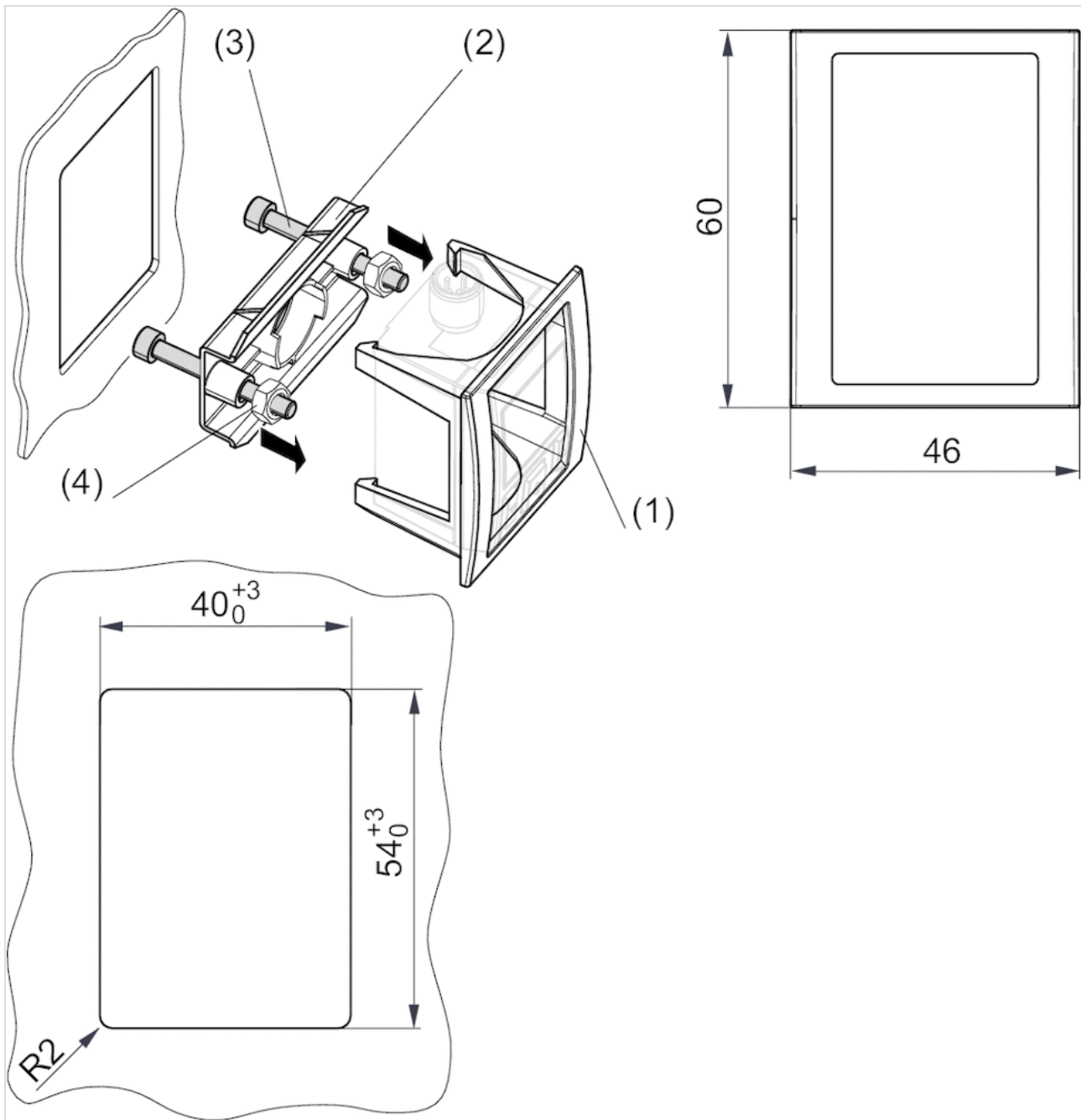

1 front frame (1), 1 wall mounting (2), 2 attachment screws M4x40 (3), 2 hexagonal nuts (4)  
Panel plate thickness max. 5.0 mm

# Efficient pneumatic solutions, our program: cylinders and drives, valves and valve systems, air supply management



Visit us: [Emerson.com/Aventics](https://www.emerson.com/Aventics)

Your local contact: [Emerson.com/contactus](https://www.emerson.com/contactus)



Emerson.com



[Facebook.com/EmersonAutomationSolutions](https://www.facebook.com/EmersonAutomationSolutions)



[LinkedIn.com/company/Emerson-Automation-Solutions](https://www.linkedin.com/company/Emerson-Automation-Solutions)



[Twitter.com/EMR\\_Automation](https://twitter.com/EMR_Automation)

An example configuration is depicted on the title page. The delivered product may thus vary from that in the illustration. Subject to change. This Document, as well as the data, specifications and other information set forth in it, are the exclusive property of AVENTICS GmbH. It may not be reproduced or given to third parties without its consent. Only use the AVENTICS products shown in industrial applications. Read the product documentation completely and carefully before using the product. Observe the applicable regulations and laws of the respective country. When integrating the product into applications, note the system manufacturer's specifications for safe use of the product. The data specified only serve to describe the product. No statements concerning a certain condition or suitability for a certain application can be derived from our information. The information given does not release the user from the obligation of own judgment and verification. It must be remembered that the products are subject to a natural process of wear and aging.

The Emerson logo is a trademark and service mark of Emerson Electric Co. Brand logotype are registered trademarks of one of the Emerson family of companies. All other marks are the property of their respective owners. © 2017 Emerson Electric Co. All rights reserved.  
2019-03



## CONSIDER IT SOLVED™