

New

Flow



VA 550 / 570

New precise flow measurement for
compressed air and gases
incl. temperature measurement



ATEX





VA 550

Precise flow measurement for compressed air and gases

Application range:

- Ideal also for the outdoor area
- Compressed air measurement and distribution
- Leakage measurement of compressed air and gases
- Flow measurement of gases like e. g. nitrogen, argon, carbon dioxide, oxygen and so on
- Flow measurement in vacuum systems
- Flow measurement of explosive gases like natural gas, methane, propane, hydrogen with ATEX approval
- Flow measurement of corrosive, acid gases like e. g. biogas with different gas mixtures
- Measurement of oxygen and natural gas at gas burners
- Flow measurement of gas mixtures like e. g. forming gas



* German Technical and Scientific Association for Gas and Water

Applicable in all sectors like e. g.:

- Chemistry, petro chemistry
- Natural gas, methane...
- Pharmaceutical industry
- Food production
- Breweries
- Diaries
- Power plants
- Semiconductor/ electronics
- Automotive industry



VA 550
immersion
sensor



The new flow sensors VA 550/ 570 work according to the calorimetric measuring principle. Therefore an additional temperature and pressure compensation is not necessary.

Due to its robust design, the aluminum die cast housing, the robust sensor tip made from stainless steel 1,4571, the new VA 550/ 570 are suitable for demanding industrial applications. An ATEX version is available for applications in explosive areas. For flow measurement e. g. of natural gas there is a version with a DVGW admission.

Contrary to the previously used bridge circuit the newly developed evaluation electronics records all measured values digitally. This allows very precise and fast measurements with a wide temperature range of up to 180 °C. The measuring span is 1...1000 and enables therefore measurements in very low as well as in very high flow speeds of up to 224 m/s.

VA 550/ 570 has an integrated Modbus output as a standard with which all parameters like Nm³/h, Nm³, Nm/s, NI/min, NI/s, kg/h, kg/min, ft/min, °C etc. can be transferred. All parameters can be adjusted directly at the instrument (via display) or via the PI 500 hand-held measuring instrument resp. the Service Software. Of course there are also 1 x 4...20 mA analogue output available for the flow and a galvanically isolated pulse output for the total consumption.

A remote diagnosis can be carried out via Modbus and all relevant parameters can be checked and changed if necessary. So it is possible to change e. g. the gas type, the inner diameter, the scaling and so on or the zero point resp. the leak flow volume suppression in case of changed process conditions.

Via remote diagnosis and status update e. g. temperature exceedings, failures of the sensor or the calibration date can be determined.



VA 570 - with integrated measuring section



Flanged version

Version with pipe thread
R thread or NPT thread

VA 570 is supplied with an integrated measuring section. The measuring sections are available in flanged version or with R resp. NPT thread.

A special feature is the removable measuring head. So the measuring unit can be removed easily and quickly for calibration or cleaning purposes without having to dismount the measuring section intricately. During this period the measuring section is sealed by a closing cap (accessory).

The screwing with centering device ensures that the sensor is positioned accurately in the center when screwing it into the measuring section furthermore it grants an exact positioning in the flow direction. This avoids unnecessary measuring faults.

Flow measuring ranges VA 570								
			Full scale values in Nm³/h					
Inch	Inner pipe diameter (mm)	DN	Air	N2	Ar	O2	CO2	Methane natural gas (CH4)
R 1/2"	16.1	DN 15	0.2...90	0.2...80	0.2...140	0.2...85	0.2...90	0.2...50
R 3/4"	21.7	DN 20	0.3...170	0.3...155	0.3...275	0.3...165	0.3...175	0.3...105
R 1"	27.3	DN 25	0.5...290	0.5...260	0.5...460	0.5...280	0.5...290	0.5...170
R 1 1/4"	36.0	DN 32	0.7...530	0.7...485	0.7...830	0.7...505	0.7...525	0.7...310
R 1 1/2"	41.9	DN 40	1.0...730	1.0...650	1.0...1140	1.0...695	1.0...720	1.0...430
R 2"	53.1	DN 50	2.0...1195	2.0...1060	2.0...1870	2.0...1140	2.0...1185	2.0...705
	68.9	DN 65	4.0...2050	3.0...1820	6.0...3205	3.0...1955	4.0...2030	2.0...1210
	80.9	DN 80	5.0...2840	5.0...2610	9.0...4440	5.0...2710	5.0...2810	3.0...1680

If you want to measure the flow of a special gas mixture please contact us. On request we are quite pleased to offer a real gas calibration under process conditions.

Measuring ranges of further gases like: Nitrous oxide (N2O), helium (He), propane (C3H8), biogas* (CH4/CO2 60/40) on request!



Measuring head removable

Screwing with centring device

Easy cleaning of the sensor system



VA 550 - immersion sensor

Flow sensor for heavy duty industrial applications incl. temperature measurement.



The immersion sensor VA 550 is the ideal flow sensor for installation into existing compressed air resp. gas lines from 3/4" up to DN 1000.

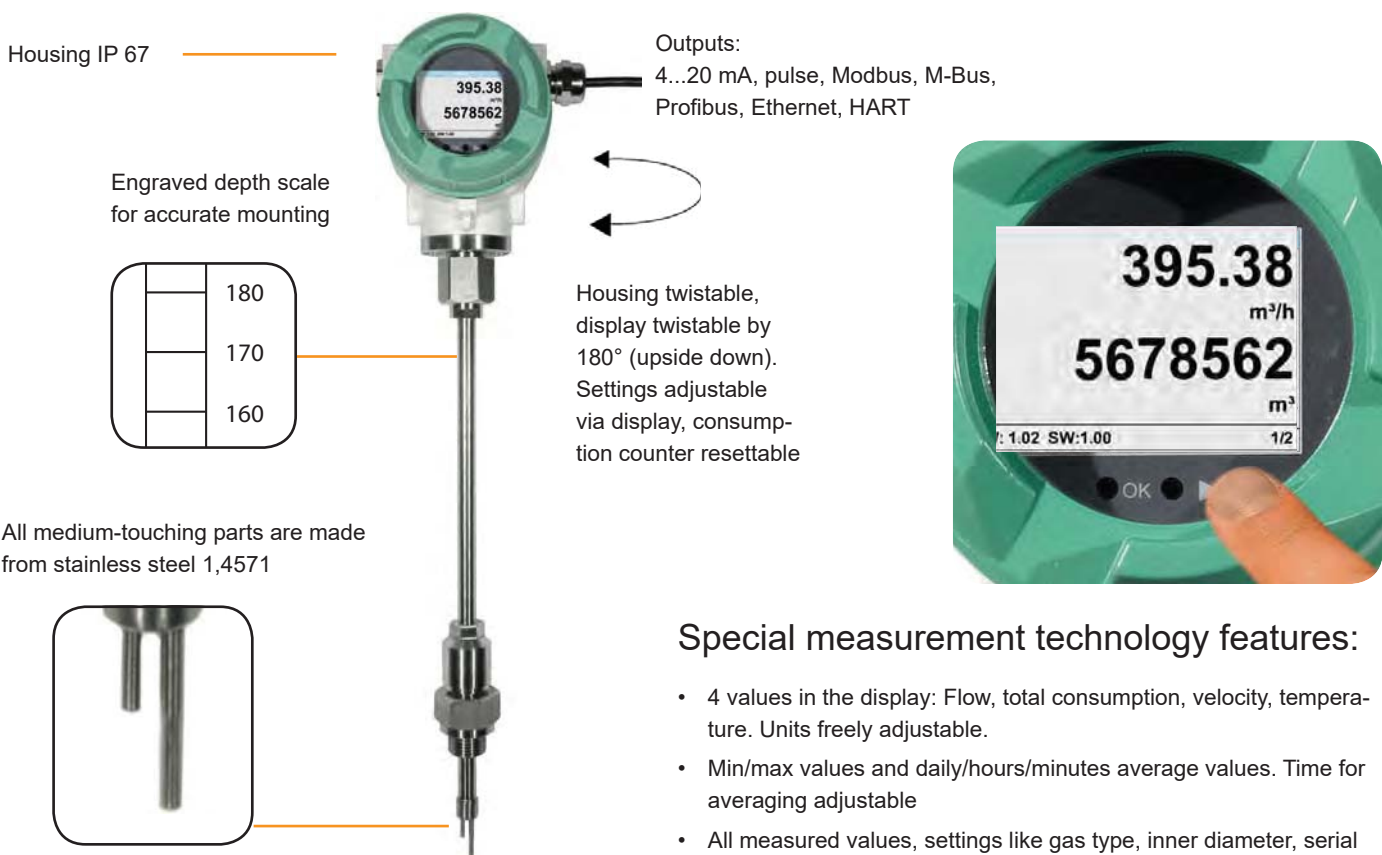

Special mechanical features:

- Robust impact-proof aluminum die cast housing for the outdoor area IP 67
- All medium-touching parts made from stainless steel 1,4571
- As immersion sensor suitable for 3/4" up to DN 1000
- On request with ATEX approval ATEX II 2G Ex d IIC T4 (up to 120 °C)
- On request with DVGW approval for natural gas (up to 16 bar)
- Pressure range up to 50 bar, special version up to 100 bar
- Temperature range up to 180 °C
- No moving parts, no wearout
- Sensor tip very robust, easy to clean
- Easy mounting and dismounting under pressure via 1/2" ball valve
- Housing twistable, display twistable by 180°
- Safety ring for mounting and dismounting under pressure
- Depth scale for precise installation

Special measurement technology features:

- 4 values in the display: Flow, total consumption, velocity, temperature. Units freely adjustable.
- Min/max values and daily/hours/minutes average values. Time for averaging adjustable
- All measured values, settings like gas type, inner diameter, serial number and so on retrievable via Modbus RTU
- Comprehensive diagnosis functions readable at the display or remote access via Modbus like e. g. exceeding of max/min values °C, calibration cycle, error codes, serial number. All parameters readable and adjustable
- Notification in case of exceeding of the calibration cycle
- Standard version accuracy 1.5 % of m.v. ± 0.3 % of f.s.
- Precision version accuracy 1.0 % of m.v. ± 0.3 % of f.s. up to 40 calibration points with certificate
- Measuring span of 1 : 1000 (0.1 up to 224 m/s)
- Configuration and diagnosis via display, hand-held instrument PI 500, PC service software on-site
- Gas type (air, nitrogen, oxygen, argon and so on) freely adjustable via PC service software or external device DS 400, DS 500, PI 500
- Reference conditions °C and mbar/hPa freely adjustable
- Zero-point adjustment, leak flow volume suppression
- Pressure loss negligible
- Flow measurement in both directions via flow direction switch



Easy mounting/dismounting of VA 550 under pressure - without disconnection of the line - without emptying the line

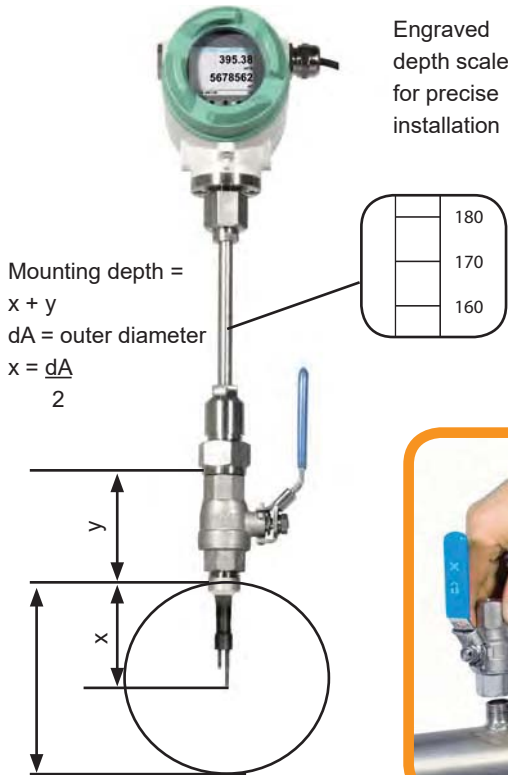

If there is no suitable measuring site with 1/2" ball valve there are two simple possibilities to set up a measuring point:

A Weld on a 1/2" screw neck and screw on a 1/2" ball valve

B Mount spot drilling collar including ball valve

By means of the drilling jig it is possible to drill under pressure through the 1/2" ball valve into the existing pipeline. The drilling chips are collected in a filter. Then the sensor can be mounted.



A Screw neck
Order no.: 3300 0006

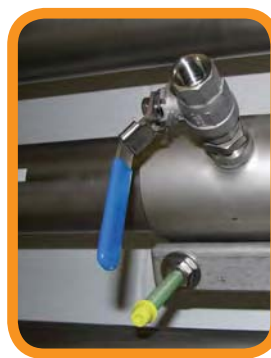

B Spot drilling collars
Order nos.: please see page 99



Drilling under pressure with CS drilling jig
Order no.: 0530 1108

Measuring ranges flow VA 550 - immersion sensor																					Re- com- men- ded sen- sor length
Inner diameter of pipe			Standard version (92.7 m/s)							Max. version (185.0 m/s)							High-Speed version (224.0 m/s)				
			Full scale values in Nm ³ /h *							Full scale values in Nm ³ /h *							Full scale values in Nm ³ /h *				
Inch	mm	DN	Air**	N ₂	Ar	O ₂	CO ₂	Methane nat. gas (CH ₄)	Air**	N ₂	Ar	O ₂	CO ₂	Methane nat. gas (CH ₄)	Air**	N ₂	Ar	O ₂	CO ₂	Methane nat. gas (CH ₄)	
1/2"	16.1	DN 15	45	40	71	43	45	26	90	80	142	86	90	53	110	98	172	105	109	65	160 mm
3/4"	21.7	DN 20	89	79	139	85	88	52	177	158	278	169	176	105	215	191	336	205	213	127	
1"	27.3	DN 25	122	108	191	116	120	72	243	216	381	232	241	144	295	262	461	281	292	174	
1 1/4"	36.0	DN 32	266	236	416	254	263	157	531	472	830	506	526	314	643	572	1006	613	636	380	
1 1/2"	41.9	DN 40	366	324	570	348	361	215	728	647	1138	694	720	430	881	784	1378	841	872	521	
2"	53.1	DN 50	600	533	938	572	593	354	1197	1064	1872	1141	1185	708	1450	1289	2267	1382	1434	857	220 mm
2 1/2"	71.1	DN 65	1095	974	1712	1044	1083	647	2186	1944	3418	2085	2164	1293	2647	2354	4139	2524	2619	1566	
3"	84.9	DN 80	1569	1395	2454	1497	1553	928	3133	2786	4897	2987	3101	1852	3793	3373	5931	3617	3753	2244	
4"	110.0	DN 100	2644	2351	4134	2522	2616	1563	5278	4693	8251	5033	5224	3121	6391	5683	9992	6094	6322	3780	300 mm
5"	133.7	DN 125	3921	3477	6115	3730	3870	2312	7807	6942	12205	7444	7727	4617	9453	8406	14779	9014	9352	5591	
6"	159.3	DN 150	5579	4942	8691	5302	5500	3287	11096	9867	17347	10581	10982	6562	13436	11948	21006	12812	13292	7947	
8"	200.0	DN 200	8816	7809	13733	8378	8690	5193	17533	15590	27409	16718	17353	10368	21229	18879	33190	20244	21002	12557	
10"	250.0	DN 250	13742	12216	21483	13106	13595	8124	27428	24389	42877	26153	27147	16220	33211	29534	51921	31669	32855	19644	
12"	300.0	DN 300	19836	17613	30972	18895	19601	11713	39544	35162	61817	37706	39138	23384	47880	42579	74856	45657	47367	28322	

* Nm³/h according to DIN 1343: 0°C, 1013.25 hPa for gases
** ISO 1217: 20°C, 1000 hPa for air

Measuring ranges of further gases like: Nitrous oxide (N₂O), helium (He), propane (C₃H₈), biogas* (CH₄/CO₂ 60/40) on request!

If you want to measure the flow of a special gas mixture please contact us. On request we are quite pleased to offer a real gas calibration under process conditions.



Configuration of VA 550 via PC Service Software

In general all configurations can be done via the integrated display. For sensors without display there is a PC Service Software available. The following adjustments can be carried out directly at the display resp. by means of the PC Service Software:

- Adjustment of inner diameter of pipe
- Selection of gas type
- Selection of units: e.g. m³/h, m³/min, l/min, kg/s,...
- Reset of counter
- Setting of reference conditions (reference temperature/pressure)
- Zero point adjustment / leak flow volume suppression
- Scaling of 4...20 mA output / setting of pulse weight
- Adjustment of Modbus settings



Configuration of VA 550 on-site via hand-held instrument PI 500

For configuration of VA 550 on-site or in the outdoor area where the work with a laptop is hardly possible we recommend to use the hand-held instrument PI 500.

By means of PI 500 all sensors without display can be configured via the menu navigation in the hand-held instrument. The adjustment possibilities are the same ones as indicated above with PC Service Software or via integrated display. The lithium-ion battery integrated in PI 500 grants the power supply of the sensor also on-site during the configuration.

Mobile measurement with hand-held measuring instrument PI 500

Together with the hand-held instrument PI 500 the sensor VA 550 can also be used as a portable measuring solution.

PI 500 has an integrated data logger for long-term storage.

The data can be exported to a USB stick.

Furthermore, additional sensors can be connected to PI 500 like e. g. pressure sensors, dew point sensors, temperature sensors and optional third-party sensors with the following signals:

0...1/10 V, 0/4...20 mA, Pt 100, Pt 1000, pulse, Modbus.

Evaluation with chart recorder DS 500 / DS 400

For applications without process control or if additional data loggers are required VA 550 can also be operated with the chart recorders DS 500 or DS 400.

It is possible to connect up to 12 sensors to one DS 500 and up to 4 sensors to one DS 400. The data logger (for up to 100 million measured values) can be evaluated via USB stick or via Ethernet interface.





Operation / configuration also in explosive areas

The optical keys integrated in the display also function through the glass pane. Advantage: The sensor VA 550 can also be configured in explosive areas without having to open the housing. In case of conventional keys the housing has to be opened for operation. In an explosive area this is often not possible.

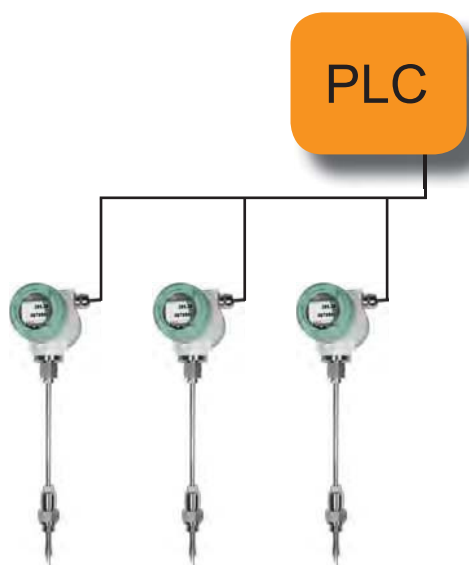

Modbus interface ingetrated as a standard

Modern building management systems require modern sensors with digital Modbus interface.

In case of the flow sensors VA 550 the measured values like:

- Volume flow in Nm³/h, Nm³/min and so on
- Gas/air temperature
- Additional average value calculations: For all parameters freely adjustable from 1 minute to 1 day, e. g. 1/2 hours average value, average day value

as well as diagnosis values like:

- Date of the last calibration
- Maximum temperature which was reached
- Sensor diagnosis, error codes

can be accessed via the Modbus RTU protocol.

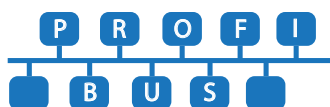

Optionally: Connection to different Bus systems

There are different options available for connection to modern Bus systems:

- Profibus DP interface
- Profinet interface
- Ethernet interface (Modbus-TCP)
- M-BUS



Ethernet
Modbus-TCP

M-BUS



Technical data VA 550/ 570

Measuring range VA 550:	0.1...92,7 Nm/s, standard version* 0.1...185 Nm/s, max. version* 0.1...224 Nm/s, high speed version*
	* measuring ranges Nm ³ /h for different pipe diameters and gases, see table flow measuring ranges * all measured values referred to DIN 1343 standard conditions 0 °C and 1013 mbar ex factory
Accuracy: accuracy class (m.v.: of meas. value) (f.s.: of full scale)	± 1.5 % of m.v. ± 0.3 % of f.s. <u>on request</u> ± 1.0 % of m.v. ± 0.3 % of f.s.
Accuracy indications	referred to ambient temperature 22°C ± 2°C, system pressure 6 bar
Repeatability:	0.25 % of m.v. in case of correct mounting (mounting aid, position, inlet section)
Measuring principle:	Thermal mass flow sensor, the measuring effect is based on the cooling down of a heated sensor PT 45 by bypassing gas. The ambient temperature is measured with a PT 100. An additional pressure and temperature compensation is not necessary.
Response time:	t90 < 3 s
Operating temperature range probe tube/display unit:	-40...180 °C probe tube -40...70°C display unit -40...120°C for ATEX version
Adjustment possibilities via display, external hand-held meter PI 500, PC Service Software, remote diagnosis:	Nm ³ /h, Nm ³ /min, NI/min, l/s, ft/min, cfm, kg/h, kg/min, inner diameter, reference conditions °C/°F, mbar/hPa, zero-point correction, leak flow volume suppression, scaling of analogue output 4...20 mA, pulse/alarm, error codes and so on
Adjustment possibilities via external device DS 400, DS 500	Gas type
Outputs:	<u>Standard:</u> Modbus RTU, 4...20 mA activ (not galv. isolated), galvanically isolated pulse (pulse weight freely selectable), alarm relais (max. 48 VDC, 0.5A) <u>Optional:</u> 2 x 4...20 mA outputs galvanically isolated Ethernet Interface (Modbus/TCP) Profibus DP HART-Protocol Profinet 2 x 4...20 mA outputs passive M-Bus
Burden:	500 Ohm
Additional average value calculation:	for all parameters freely adjustable from 1 minute up to 1 day, e. g. 1/2 hours average value, average day value
Protection class :	IP 67
Material:	Housing aluminium die cast, probe tube stainless steel 1,4571
Screw-in thread:	G 1/2" ISO 228, NPT 1/2", R 1/2", PT 1/2" available
Operating pressure VA 550:	50 bar; in special version 100 bar (For DVGW approval max. 16 bar)
Operating pressure VA 570:	16 bar; in special version 40 bar
Power supply:	18...36 VDC, 5 W
Approval:	ATEX II 2G Ex d IIC T4, DVGW

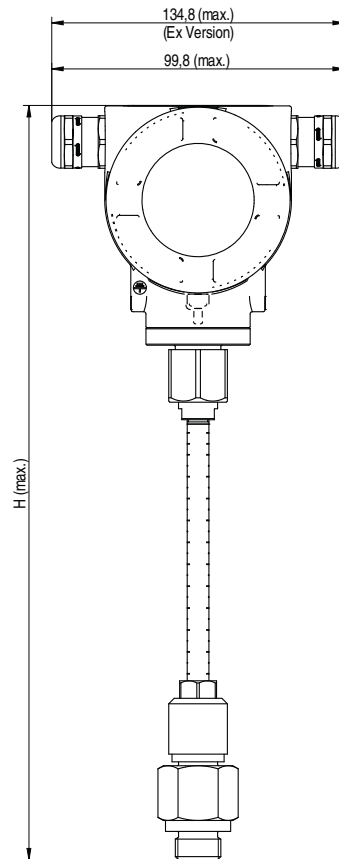

Sensor length	L [mm]	H [mm]
C1	220	441
C2	300	521
C3	400	621
C4	500	721
C5	600	821
C7	160	361

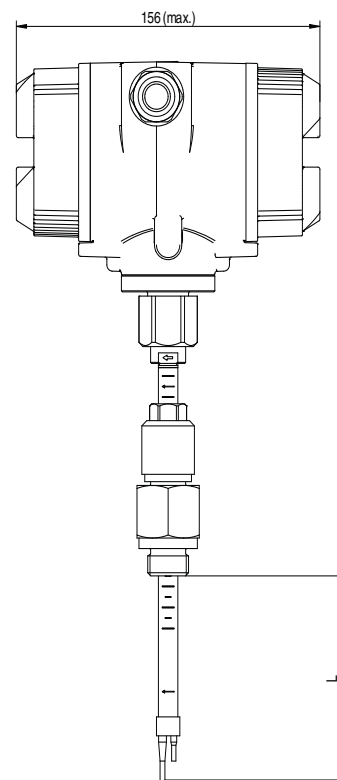

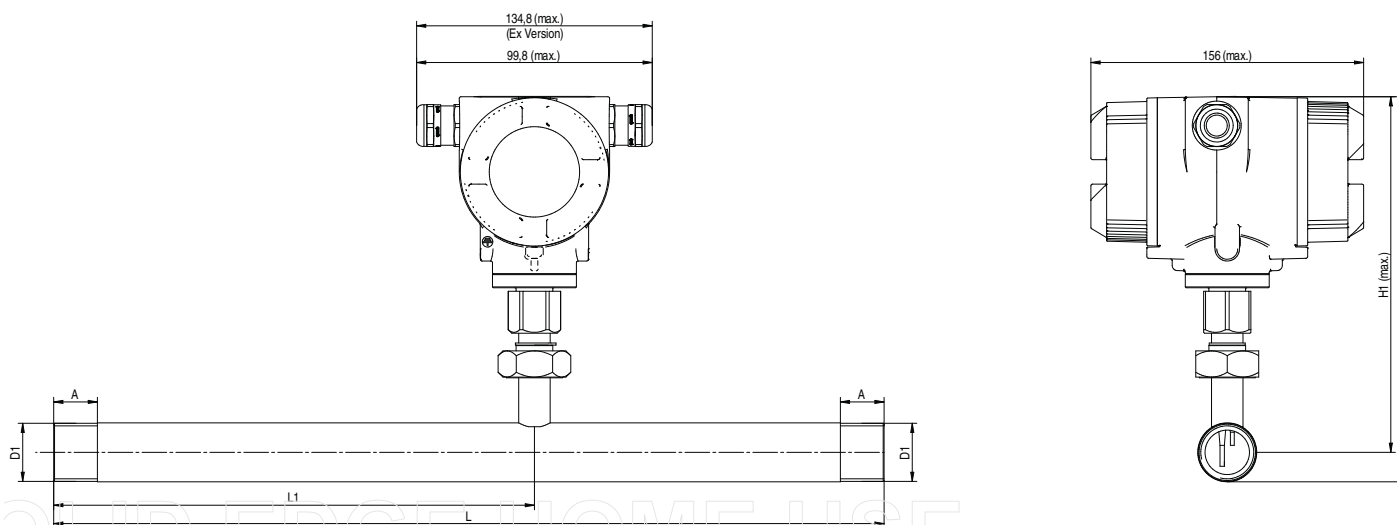

VA 570 - threaded version

Conection thread	Outer pipe diam. mm	Inner pipe diam. mm	L mm	L1 mm	H mm	H1 mm	A mm
R 1/2"	21.3	16.1	300	210	176.4	165.7	20
R 3/4"	26.9	21.7	475	275	179.2	165.7	20
R 1"	33.7	27.3	475	275	182.6	165.7	25
R 1 1/4"	42.4	36.0	475	275	186.9	165.7	25
R 1 1/2"	48.3	41.9	475*	275	186.9	165.7	25
R 2"	60.3	53.1	475*	275	195.9	165.7	30

*Attention: Shortened inlet section! Please observe the recommended minimum inlet section (length = 15 x inner diameter)

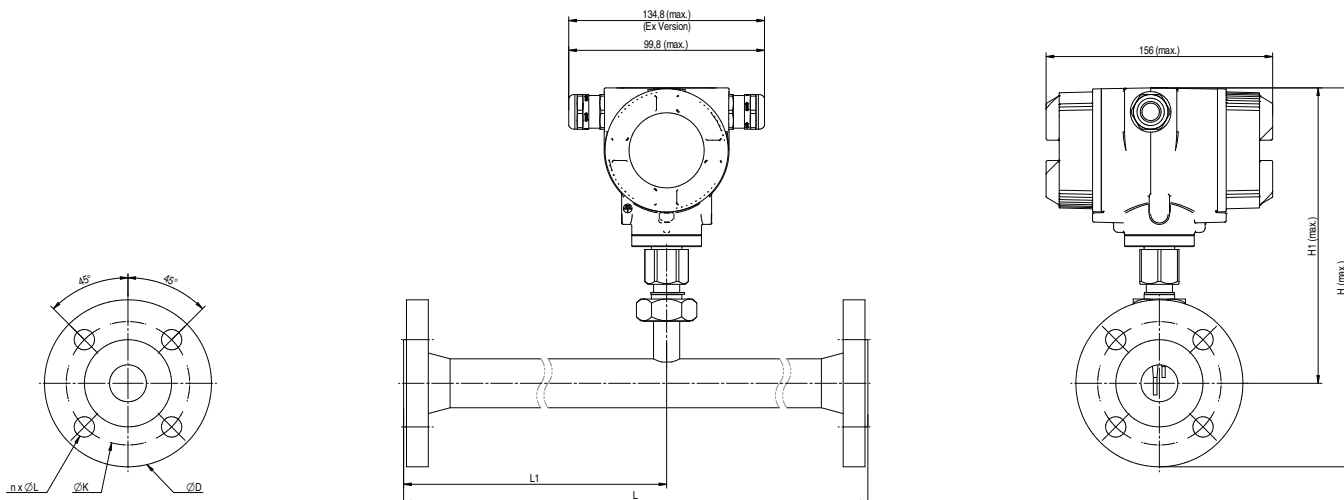

VA 570 - flanged version

Measuring section	Outer pipe diam. mm	Inner pipe diam. mm	L mm	L1 mm	H mm	H1 mm	Flange DIN EN 1092-1		
							Ø D	Ø K	n x Ø L
DN 15	21.3	16.1	300	210	213.2	165.7	95	65	4 x 14
DN 20	26.9	21.7	475	275	218.2	165.7	105	75	4 x 14
DN 25	33.7	27.3	475	275	223.2	165.7	115	85	4 x 14
DN 32	42.4	36.0	475	275	235.7	165.7	140	100	4 x 18
DN 40	48.3	41.9	475*	275	240.7	165.7	150	110	4 x 18
DN 50	60.3	53.1	475*	275	248.2	165.7	165	125	4 x 18
DN 65	76.1	68.9	475	275	268.2	175.7	185	145	8 x 18
DN 80	88.9	80.9	475	275	275.7	175.7	200	160	8 x 18

*Attention: Shortened inlet section! Please observe the recommended minimum inlet section (length = 15 x inner diameter)



VA 570 with measuring section

Example order code: **A 1 B 1 C 1 D 1 E 1 F 1 G 1 H 1 I 1 J 2 K 1 R 1**

Outer thread measuring section		
A1	R outer thread	A1
A2	NPT outer thread	A2
A3	Flange version	A3
Option display		
B1	with integrated display	B1
B2	without display	B2
Option signal output / Bus connection		
C1	2 x 4...20 mA analogue output galv. isolated, pulse output RS 485 (Modbus-RTU)	C1
C2	Profibus DP, 2 x 4...20 mA analogue output galv. isolated, pulse output RS 485 (Modbus-RTU)	C2
C3	Profibus DP, RS 485 (Modbus-RTU), pulse output (no analogue outputs)	C3
C4	1 x 4...20mA analogue output not galvanically isolated, pulse output, RS485 (Modbus-RTU)	C4
C5	Ethernet interface (Modbus-TCP), RS 485 (Modbus-RTU), pulse output (no analogue outputs)	C5
C7	2 x 4...20 mA analogue output passive, pulse output RS 485 (Modbus-RTU)	C7
C8	M-Bus	C8
Calibration		
D1	no real gas calibration - gas adjustment via gas constant	D1
D2	real gas calibration in the gas type as selected below	D2
Gas type		
E1	compressed air	E1
E2	nitrogen (N2)	E2
E3	argon (Ar)	E3
E4	carbon dioxide (CO2)	E4
E5	oxygen (O2)	E5
E6	nitrous oxide (N2O)	E6
E7	natural gas (NG)	E7
E8	helium (He)	E8
E9	propane (C3H8)	E9
E10	methane (CH4)	E10
E11	biogas (Methan 50% : CO2 50%)	E11
E12	hydrogen (H2)	E12
E90	further gas / please indicate gas type (on request)	E90
E91	gas mixture / please indicate mixture ratio (on request)	E91
Reference conditions		
F1	20°C, 1000 hPa	F1
F2	0°C, 1013,25 hPa	F2
F3	15°C, 981 hPa	F3
F4	15°C, 1013,25 hPa	F4
Maximum pressure		
G1	16 bar	G1
G2	40 bar	G2
Surface condition		
H1	standard version	H1
H2	special cleaning - oil and grease free (e. g. for oxygen applications and so on)	H2
H3	Silicone free version including special cleaning oil and grease free	H3
Accuracy class		
I1	± 1.5% of measured value (standard)	I1
I2	± 1% of measured value (precision)	I2
Maximum gas temperature at the sensor tip		
J1	up to 120°C gas temperature (only for ATEX version)	J1
J2	up to 180°C gas temperature (standard version)	J2
Approvals		
K1	Non-explosive area - no approval	K1
K2	ATEX II 2G Ex d IIC T4	K2
K3	DVGW approval (for natural gas)	K3
Special measuring range		
R1	Special measuring range (Please indicate in case of order)	R1



VA 550 Immersion sensor

Example order code: **A 1 B 2 C 1 D 1 E 1 F 1 G 1 H 1 I 1 J 1 K 2 L 1 M 1 R 1**

Measuring range (see table)		
A1	Standard version (92,7 m/s)	A1
A2	Max version (185 m/s)	A2
A3	High-Speed version (224 m/s)	A3
Screw-in thread		
B1	G 1/2" outer thread	B1
B2	1/2" NPT outer thread	B2
B3	PT 1/2" outer thread	B3
Mounting length / shaft length		
C1	220 mm	C1
C2	300 mm	C2
C3	400 mm	C3
C4	500 mm	C4
C5	600 mm	C5
C7	160 mm	C7
Option display		
D1	with integrated display	D1
D2	without display	D2
Option signal outputs / bus connection		
E1	2 x 4...20 mA analogue output galv. isolated, pulse output RS 485 (Modbus-RTU)	E1
E2	Profibus DP, 2 x 4...20 mA analogue output galv. isolated, pulse output RS 485 (Modbus-RTU)	E2
E3	Profibus DP, RS 485 (Modbus-RTU), pulse output (no analogue outputs)	E3
E4	1 x 4...20mA analogue output not galvanically isolated, pulse output, RS485 (Modb.RTU)	E4
E5	Ethernet interface (Modbus-TCP), RS 485 (Modbus-RTU), pulse output (no analogue outputs)	E5
E7	2 x 4...20 mA analogue output passive, pulse output RS 485 (Modbus-RTU)	E7
E8	M-Bus	E8
Calibration		
F1	no real gas calibration - gas adjustment via gas constant	F1
F2	real gas calibration in the gas type as selected below	F2
Gas type		
G	Compressed air G1 , nitrogen (N2) G2 , argon (Ar) G3 , carbon dioxide (CO2) G4 , oxygen (O2) G5 , nitrous oxide (N2O) G6 , natural gas (NG) G7 , helium (He) G8 , propane (C3H8) G9 , methane (CH4) G10 , biogas (methane 50% : CO2 50%) G11 , hydrogen (H2) G12 , further gas / please indicate gas type (on request) G90 , gas mixture / please indicate mixture ratio (on request) G91	G
Maximum pressure		
H1	50 bar	H1
H2	100 bar	H2
H3	16 bar	H3
Surface condition		
I1	Standard version	I1
I2	Special cleaning - oil and grease free (e.g. for oxygen applications and so on)	I2
I3	Silicone free version including special cleaning oil and grease free	I3
Accuracy class		
J1	± 1,5% of measured value (standard)	J1
J2	± 1% of measured value (precision)	J2
Maximum gas temperature at the sensor tip		
K1	up to 120°C gas temperature (only for ATEX version)	K1
K2	up to 180°C gas temperature (standard version)	K2
Approvals		
L1	Non-explosive area - no approval	L1
L2	ATEX II 2G Ex d IIC T4	L2
L3	DVGW approval (for natural gas)	L3
Reference conditions		
M1	20°C, 1000 hPa	M1
M2	0°C, 1013,25 hPa	M2
M3	15°C, 981 hPa	M3
M4	15°C, 1013,25 hPa	M4
Special measuring range		
R1	Special measuring range (Please indicate in case of order)	R1



Order number VA 550

Description	Order no.
VA 550 flow sensor, measuring head in robust aluminium die cast housing	0695 0550 + order code A...M_

Order number VA 570

Description	Order no.
VA 570 flow sensor with integrated 1/2" measuring section	0695 0570 + order code A...K_
VA 570 flow sensor with integrated 3/4" measuring section	0695 0571
VA 570 flow sensor with integrated 1" measuring section	0695 0572
VA 570 flow sensor with integrated 1 1/4" measuring section	0695 0573
VA 570 flow sensor with integrated 1 1/2" measuring section	0695 0574
VA 570 flow sensor with integrated 2" measuring section	0695 0575
VA 570 flow sensor with integrated DN 15 measuring section with weld neck flange	0695 2570
VA 570 flow sensor with integrated DN 20 measuring section with weld neck flange	0695 2571
VA 570 flow sensor with integrated DN 25 measuring section with weld neck flange	0695 2572
VA 570 flow sensor with integrated DN 32 measuring section with weld neck flange	0695 2573
VA 570 flow sensor with integrated DN 40 measuring section with weld neck flange	0695 2574
VA 570 flow sensor with integrated DN 50 measuring section with weld neck flange	0695 2575
VA 570 flow sensor with integrated DN 65 measuring section with weld neck flange	0695 2576
VA 570 flow sensor with integrated DN 80 measuring section with weld neck flange	0695 2577
Closing cap for measuring section in aluminium	0190 0001
Closing cap for measuring section stainless steel 1.4404	0190 0002

Further accessories

Description	Order no.
Connection cable for sensors 5 m with open ends	0553 0108
Connection cable for sensors 10 m with open ends	0553 0109
Mains unit in wall housing for maximum 2 sensors of the series VA/FA 5xx, 100-240 V, 23 VA, 50-60 Hz / 24 VDC, 0.35 A	0554 0110
ISO calibration certificate at 5 measuring points	3200 0001
Additional calibration point for volume flow (point freely selectable)	0700 7720
CS Service Software VA 550 incl. interface cable to PC (USB) and power supply - for configuration / parametrization of VA 550	0554 2007
As a portable hand-held instrument for configuration of VA 550/570 on-site we recommend to use the PI 500 :	
PI 500 portable hand-held instrument with integrated data logger	0560 0511
CS Soft Basic - data evaluation in graphic and table form - reading out of the measured data via USB or Ethernet	0554 7040
Transportation case	0554 6510
High-pressure protection f. installation from 10 to 100 bar (for VA 550)	0530 1115
High-pressure protection f. installation from 10 to 16 bar DVGW (for VA 550)	0530 1116
PNG cable screwing - standard VA 550/570	0553 0552
PNG cable screwing - for ATEX version VA 550/570	0553 0551