



- ATEX / IECEx certified for Gases and Dusts
- Measurement in Zone 0/20
- Direct power supply without zener barrier
- Easy plug-in mounting
- Quick and safe installation
- Junction box Ex e integrated
- No variants only one basic unit
- Enhanced temperature range -40 ... +70 °C
- Degree of protection IP66
- Analog outputs switchable between mA and V
- Outputs calibrated and scaled
- Integrated display
- Onsite parameterization
- LED status indication
- Low power input <3 W
- Cable length from the transducer to the sensor up to 100 m
- Highly resistant against corrosion by use of high-tech polymer and stainless steel



TR.Ex + IY.Ex Manual

BA.0001.05.EN

Assembly and installation instructions for safe use of explosion-proof transducer TR.Ex with mA/V output and sensors IY.Ex for Temperature, Humidity, Dew point, Differential pressure, Volume flow measurement



ATEX Documentation

D Alle Betriebsanleitungen für ATEX Ex bezogene Produkte stehen in den Sprachen Englisch, Deutsch und Französisch zur Verfügung. Sollten Sie die Betriebsanleitungen für Ex-Produkte in Ihrer Landessprache benötigen, setzen Sie sich bitte mit Ihrem örtlichen Vertreter in Verbindung.

GB All instruction manuals for ATEX Ex related products are available in English, German and French. Should you require Ex related instructions in your local language, please contact your nearest office or representative.

F Tous les manuels d'instruction des produits ATEX Ex sont disponibles en langue anglaise, allemande et française. Si vous nécessitez des instructions relatives aux produits Ex dans votre langue, veuillez bien contacter votre représentant le plus proche.

P Todos os manuais de instruções referentes aos produtos Ex da ATEX estão disponíveis em Inglês, Alemão e Francês. Se necessitar de instruções na sua língua relacionadas com produtos Ex, deverá entrar em contacto com a delegação mais próxima ou com um representante.

DK Alle brugervejledninger for produkter relateret til ATEX Ex er tilgængelige på engelsk, tysk og fransk. Skulle De ønske yderligere oplysninger om håndtering af Ex produkter på eget sprog, kan De rette henvendelse herom til den nærmeste afdeling eller forhandler.

SF Kaikkien ATEX Ex -tyyppisten tuotteiden käyttöohjeet ovat saatavilla englannin-, saksan- ja ranskankielisinä. Mikäli tarvitsette Ex -tyyppisten tuotteiden ohjeita omalla paikallisella kielellänne, ottakaa yhteyttä lähimpään toimistoon tai edustajaan.

I Tutti i manuali operativi di prodotti ATEX contrassegnati con Ex sono disponibili in inglese, tedesco e francese. Se si desidera ricevere i manuali operativi di prodotti Ex in lingua locale, mettersi in contatto con l'ufficio più vicino o con un rappresentante.

E Todos los manuales de instrucciones para los productos antiexplosivos de ATEX están disponibles en inglés, alemán y francés. Si desea solicitar las instrucciones de estos artículos antiexplosivos en su idioma local, deberá ponerse en contacto con la oficina o el representante de más cercano.

S Alla instruktionsböcker för ATEX Ex (explosionssäkra) produkter är tillgängliga på engelska, tyska och franska. Om Ni behöver instruktioner för dessa explosionssäkra produkter på annat språk, skall Ni kontakta närmaste eller representant.

NL Alle handleidingen voor producten die te maken hebben met ATEX explosiebeveiliging (Ex) zijn verkrijgbaar in het Engels, Duits en Frans. Neem, indien u aanwijzingen op het gebied van explosiebeveiliging nodig hebt in uw eigen taal, contact op met de dichtstbijzijnde vestiging van of met een vertegenwoordiger

GR Όλα τα εγχειρίδια λειτουργιάζτρω προιουτρω με ATEX Ex διατιθευται στα Αγγλικά, Γερμανικά και Γαλλικά. Σε

περιπτωση που χρειαζετε οδηγιεζ σχετικα με Ex στη τοπικη γλωσσα παρακαλουμε επικοινωνηστε με το πλησιεστερο γραφειο τηζ η αντιπροσωπο τηζ

PL Wszystkie instrukcje obsługi dla urządzeń w wykonaniu przeciwwybuchowym Ex, zgodnych z wymaganiami ATEX, dostępne są w języku angielskim, niemieckim i francuskim. Jeżeli wymagana jest instrukcja obsługi w Państwa lokalnym języku, prosimy o kontakt z lokalnym przedstawicielem.

SK Všetky návody na obsluhu pre prístroje s ATEX Ex sú k dispozícii v jazyku anglickom, nemeckom a francúzskom. V prípade potreby návodu pre Ex- prístroje vo Vašom národnom jazyku, skontaktujte prosím miestnu kanceláriu firmy.

SLO Vsi predpisi in navodila za ATEX Ex sorodni pridelki so pri roki v angleščini, nemščini ter francoščini. Če so Ex sorodna navodila potrebna v vašem tukejnem jeziku, kontaktirajte vaš najbliži office ili predstavnika.

CZ Všechny uživatelské příručky pro výrobky, na něž se vztahuje nevýbušné schválení ATEX Ex, jsou dostupné v angličtině, němčině a francouzštině. Požadujete-li pokyny týkající se výrobků s nevýbušným schválením ve vašem lokálním jazyku, kontaktujte prosím vaši nejbližší reprezentační kancelář

H Az ATEX Ex műszerek gépkönyveit angol, német és francia nyelven adjuk ki. Amennyiben helyi nyelven kérik az Ex eszközök leírásait, kérjük keressék fel a legközelebbi irodát, vagy képviselőt.

BG Всички упътвания за продукти от серията ATEX Ex се предлагат на английски, немски и френски език. Ако се нуждаете от упътвания за продукти от серията Ex на родния ви език, се свържете с най-близкия офис или представителство на фирма

LT Visos gaminių ATEX Ex kategorijos Eksploatavimo instrukcijos teikiami anglų, vokiečių ir prancūzų kalbomis. Norėdami gauti prietaisų Ex dokumentaciją kitomis kalbomis susisiekite su artimiausiu bendrovės biuru arba atstovu.

RO Toate manualele de instructiuni pentru produsele ATEX Ex sunt in limba engleza, germana si franceza. In cazul in care doriti instructiunile in limba locala, trebuie sa contactati cel mai apropiat birou sau reprezentant

LV Visas ATEX Ex kategorijas izstrādājumu Lietošanas instrukcijas tiek piegādātas angļu, vācu un franču valodās. Ja vēlaties saņemt Ex ierīšu dokumentāciju citā valodā, Jums ir jāsazinās ar firmas Jokogava tuvāko ofisu vai pārstāvi

M Il-manwali kollha ta' l-istruzzjonijiet għal prodotti marbuta ma' ATEX Ex huma disponibbli bil-Ingliż, bil-Ġermaniż u bil-Franċiż. Jekk tkun teħtieġ struzzjonijiet marbuta ma' Ex fil-lingwa lokali tiegħek, għandek tikkuntattja lill-eqreb rappreżentant jew ufficiju ta'

EST Kõik ATEX Ex toodete kasutamishendid on esitatud inglise, saksa ja prantsuse keeles. Ex seadmete muukeelse dokumentatsiooni saamiseks pöörduge lähima lokagava kontori või esindaja poole

Sicherheitshinweise Safety Notes Consignes de Sécurité

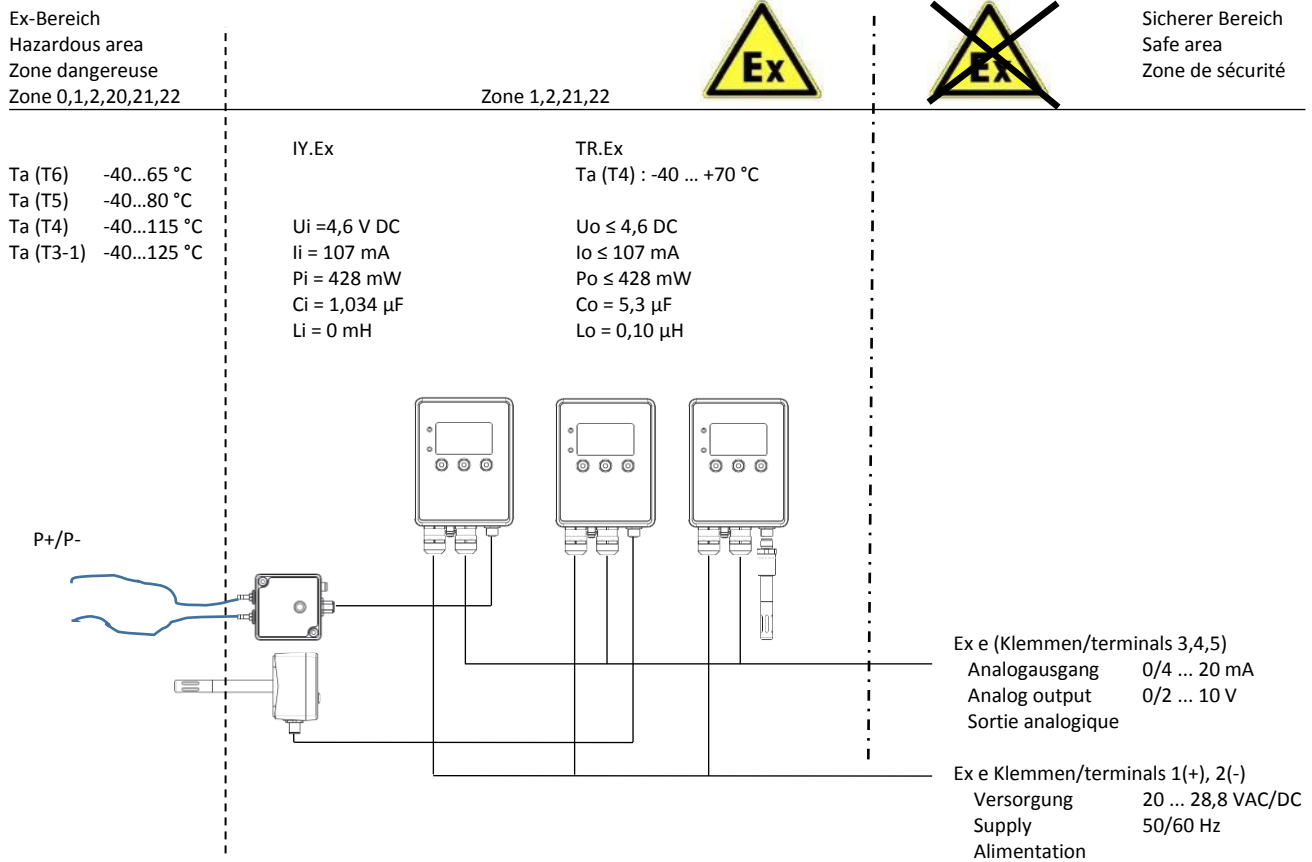

- Installieren Sie gemäß Herstellerangaben und für Sie gültigen Normen und Regeln.
 - Das Entriegeln des Gerätes oder öffnen des Klemmkastens ist nur im spannungslosen Zustand gestattet.
 - Beim Einbau des Gerätes ist darauf zu achten, dass die Gehäuseschutzart IP66 nach EN 60529 eingehalten wird.
 - Dieses Betriebsmittel kann nach Herstellerangaben in der Zone 1, 21 (II 2GD) bzw. Zone 22 (II 3GD) eingesetzt werden.
 - Der Sensorstromkreis darf in die Zone 0 (II 1G) eingeführt werden. Entspricht der Bezeichnung II 2(1)G.
 - Die Geräte dürfen nur in Messstoffen eingesetzt werden, gegen welche die prozessberührenden Materialien beständig sind.
 - Das Gerät ist an den Potenzialausgleich (PA) anzuschließen, dazu steht ein innerer und äußerer Anschluss zu Verfügung.
 - Das Gerät ist vor mechanische Belastung und UV Licht zu schützen.
-
- Install in accordance with manufacturer's instructions and valid standards and rules.
 - Unlocking the device or opening the terminal box is only permitted with the power off.
 - When installing the unit, make sure that the housing protection type IP66 is maintained in accordance with EN 60529.
 - This equipment can be used according to manufacturers' instructions in Zone 1, 21 (II 2GD) and 22. (II 3GD).
 - The sensor circuit can be introduced into the zone 0 (II 1G). Corresponds to the designation II 2 (1) G.
 - The device may only be used in measurement media, against which the process-contacting materials are resistant.
 - The unit must be connected to the potential equalization (PA), an internal and external terminal is available.
 - The unit must be protected against mechanical impact/pressure and UV light.
-
- Installer conformément aux instructions et aux normes et règles en vigueur du fabricant.
 - Libérer l'appareil ou ouvrir la boîte à bornes ne est autorisée qu'avec l'appareil hors tension.
 - Lors de l'installation, assurez-vous que le degré de protection IP66 boîtier est maintenu conformément à la norme EN 60529.
 - Cet équipement peut être utilisé selon les instructions du fabricant dans la zone 1, 21 (II 2 GD) et 22 (II 3GD).
 - Le circuit de capteur peut être introduit dans la zone 0 (II 1G). Correspond à la désignation II 2 (1) G.
 - Le dispositif ne peut être utilisé dans de tels liquides, contre lequel les matériaux de traitement contact sont résistants.
 - L'appareil est connecté à la liaison équipotentielle (PA) pour rejoindre, ceci est une borne interne et externe à votre disposition.
 - L'appareil doit être protégé contre les chocs mécaniques et la lumière UV.

Content

ATEX Documentation	2
1. General	5
2. Product description	5
3. Technical Data	6
4. Dimension	8
5. Assembly / Installation	9
6. Commissioning	11
7. Operation	11
8. Dismantling	11
9. Calibration analog outputs	11
10. Parameterization	12
11. Error Message	13
12. Maintenance	13
13. Repair	13
14. Disposal	13
15. Accessories Spare Parts	13
Revision Status	14
EU Konformitätserklärung EU Declaration of Conformity Déclaration de Conformité UE	15
Contact Information	16
Company Information	16

1. General

The manual is included in the delivery and serves to ensure proper handling and optimum functioning of the device. The manufacturer offers no guarantee for this publication and is not liable for any improper handling of the products described. For this reason, the manual has to be read before operation. In addition, all personnel who are involved in the transport, setup, operation, maintenance and repair are to be familiar with this manual. This manual may not, without the prior written consent of the manufacturer be used for competition purposes and will not be passed on to third parties. Copies for personal use are permitted. This documentation may contain technical inaccuracies or typographical errors. The information shall be revised periodically and is subject to modifications. The manufacturer reserves the right to modify or alter the product described at any given time.

© copyright petz industries GmbH & Co. KG
All rights reserved

SYMBOLS



This sign shows
Safety notes.

Safety notes must be followed. Failure to observe may result in personal injury or property damage. The manufacturer assumes no liability.

SAFETY NOTES



Installation, electrical connection, maintenance and commissioning may only be performed by trained specialist.



Avoid excessive mechanical loads and improper use.



Switch off power when mounting and dismounting



The display loses contrast and brightness in the cold conditions. Regenerates when the temperature rises to its original state.

2. Product description

A basic unit TR.Ex and various sensors of the series IY.Ex solve a variety of measurement tasks. The sensors are available for multi-functionality, high accuracy and simple assembly.

The following sensors are available

- Temperature
- Temperature and humidity, dew point
- Differential pressure, volume flow
- Special sensors on request

In addition, the feelers/probes allow an on-site commissioning and the LCD display serves as an on-site value measurement. The integrated terminal box of protection Ex e guarantees a direct electrical connection in the hazardous area.

Due to the modular concept, separation of electronics and mounting plate, a simple, easy installation and commissioning is guaranteed.

Options such as different sensor cables for difficult installation conditions supplement the product portfolio. Calibration of the measuring chain are made as easy as possible by the design of the device.

MEASUREMENT PRINCIPLE

The physical unit is detected in the series sensors IY.Ex. The measured value is digitally processed. The transfer to the transmitter TR.Ex is carried out by an "intelligent" protocol that enables easy-to-change sensors and is open for future sensors.

The robust, interference-free signal from the sensor to transmitter allows even in harsh industrial environments to transfer up to 100 m.

In this TR.Ex transmitter, this signal is converted into freely scalable analog outputs. You can choose between voltage and current outputs which can be set by software menu.

3. Technical Data

TR.Ex TRANSDUCER

SUPPLY			
Voltage		20 – 28,8	V AC/DC
Frequency		50 – 60	Hz
Power input/consumption		3 / 5	W / VA
Protection class / over voltage category / pollution degree		III / 2 / III	insulated
OUTPUTS			
Voltage / current selectable		0 – 10 / 0 – 20	V DC / mA
Accuracy		0,1	% FS
Influence of temperature		< 0,01	%/K
Effect of load		0,1/100	%/Ohm
DISPLAY / BUTTON / LED			
LCD, backlight		128 x 64	pixel
Micro push button		> 1 Mio.	cycles
LED red / green		Status indication	
HOUSING			
High Tech Polymer	halogen-, silicon-, PVC		free
Corrosion durability	On- and Offshore		With high salinity
Ingreased protection	IP66		
GENERAL			
Terminal cross-section	0,08 – 2,5	mm	without end sleeve
ATEX/IECEX Ex e	0,25 – 1,5	mm	with end sleeve
Cable connections M20x1,5 ATEX/IECEX Ex e	6 - 13		Ø mm
Dimensions H x W x D	175 x 110 x 56		mm
Weight	800		g
MATERIALS			
Housing	High Tech Polymer		electrostatically conductive
Front plate, Screws	Stainless steel		
Seals	EPDM		
Cable connection, Sensor connection M12	brass plated		
APPLICATION			
Ambient- and storage temperature	-40 ... +70		°C
Humidity, without condensation	0 ... 100		%rH
Mountion position, altitude	any, recommendation vertical, < 2000 m		

IY.Ex -P-... DIFFERENTIAL PRESSURE / VOLUME FLOW

TYPES AND MEASUREMENT RANGE			
IY.Ex-P-0100		-100 – 100	Pa
IY.Ex-P-0250		-250 – 250	Pa
IY.Ex-P-0600		-600 – 600	Pa
IY.Ex-P-1000		-1000 – 1000	Pa
IY.Ex-P-2500		-2500 – 2500	Pa
ACCURACY			
Accuracy „total“ 100 / 250 / 600 / 1.000 / 2.500 Pa		2,0 / 2,0 / 1,5 / 1,0 / 1,0	% FS
Accuracy „typical“		< 0,5	% FS
Long term stability 1.000 h / 25 °C		0,5	%
MTTF (Sensor)		4.611.965	h
Sampling rate		0,1	s
SUPPLY Ex i			
Voltage	Ui	4,6	V
Current	Ii	0,107	A
Power	Pi	0,428	W
Capacitance	Ci	1,034	µF
Inductance	Li	0	µH
HOUSING			
High Tech Polymer	halogen-, silicon-, PVC		free
Corrosion resistance	On- and Offshore		With high salinity
MATERIALS			
Housing	High Tech Polymer		electrostatically conductive
Front plate, Screws	Stainless steel		
Seals	EPDM		
tube connection	brass plated		
APPLICATION			
Ambient- and storage temperature	-40 ... +70		°C
Humidity, without condensation	0 ... 100		%rH
Mountion position	any, recommendation vertical		

IY.Ex -RT / RTH-... TEMPERATURE / TEMPERATURE HUMIDITY DEW POINT (Room)

TYPES AND MEASUREMENT RANGE			
IY.Ex-RT	Room Temperature feeler/probe	-40 ... +125	°C
IY.Ex-RTH	Room Temperature-humidity feeler/probe	-40 ... +125 / 0 ... 100	°C / %RH
ACCURACY			
Accuracy temperature @.0 ... 60 °C		< 0,5	°C
Accuracy temperature @.-40 ... 0, @ 60 ... 125 °C		< 0,5 °C + 0,03°C/K	°C/K
Accuracy humidity		2,0	% FS
Hysteresis		1,0	%
Long term stability 1.000 h / 25 °C		0,5	%
MTTF (Sensor)		9.312.507	h
Sampling rate		0,2	s
SUPPLY EX I			
Voltage	Ui	4,6	V
Current	Ii	0,107	A
Power	Pi	0,428	W
Capacitance	Ci	0,33	µF
Inductance	Li	0	µH
MATERIALS			
Thermowell, end cap		Stainless Steel	
Seals		EPDM	
Sensor connection M12		brass plated	
Weigth		100	g
APPLICATION			
Ambient-, storage temperature		-40 ... +125	°C
Humidity, without condensation		0 ... 100	%RH
Mounting position		Any, recommendation vertical	

IY.Ex -DT / DTH-... TEMPERATURE / TEMPERATURE HUMIDITY DEW POINT (Duct)

TYPES AND MEASUREMENT RANGE			
IY.Ex-DT-50	Duct Temperature Probe 50 mm	-40 – 125	°C
IY.Ex-DT-100	Duct Temperature Probe 100 mm	-40 – 125	°C
IY.Ex-DT-200	Duct Temperature Probe 200 mm	-40 – 125	°C
IY.Ex-DTH-50	Duct Temperature Humidity Probe 50 mm	-40 – 125 / 0 – 100	°C / %RH
IY.Ex-DTH-100	Duct Temperature Humidity Probe 100 mm	-40 – 125 / 0 – 100	°C / %RH
IY.Ex-DTH-200	Duct Temperature Humidity Probe 200 mm	-40 – 125 / 0 – 100	°C / %RH
ACCURACY			
Accuracy temperature max.		< 0,5	°C
Accuracy temperature @.-40 ... 0, @ 60 ... 125 °C		< 0,5 °C + 0,03°C/K	°C/K
Accuracy humidity total error band		2,0	% FS
Hysteresis		1,0	%
Long term stability 1.000 h / 25 °C		0,5	%
MTTF (Sensor)		9.312.507	h
Sampling rate		0,2	s
SUPPLY EX I			
Voltage	Ui	4,6	V
Current	Ii	0,107	A
Power	Pi	0,428	W
Capacitance	Ci	1,034	µF
Inductance	Li	0	µH
HOUSING			
High Tech Polymer		halogen-, silicon-, PVC	free
Corrosion resistance		On- and Offshore	With high salinity
MATERIALS			
Housing		High Tech Polymer	electrostatically conductive
Front plate, Screws		Stainless steel	
Seals		EPDM	
tube connection		brass plated	
Weigth		I = 50 mm / 460	g
		I = 100 mm / 500	g
		I = 200 mm / 540	g
APPLICATION			
Ambient-, storage temperature		-40 ... +125	°C
Humidity, without condensation		0 ... 100	%RH
Mounting position		any, recommendation vertical	



Certificates

TR.Ex	ATEX IECEX	EPS 14 ATEX 1 789 X IECEX EPS 14.0101X	II2(1)G Ex eb mb ib [ia Ga] IIC T4 Gb II2(1)D Ex tb [ia Da] IIIC T130 °C Db
IY.Ex	ATEX IECEX	EPS 14 ATEX 1 789 X IECEX EPS 14.0101X	II1/2G Ex ia IIC T6/T5/T4 Ga/Gb II1/2D Ex ia IIIC T130 °C Da/Db

4. Dimension

TR.Ex (TRANSMITTER/MESSUMFORMER)

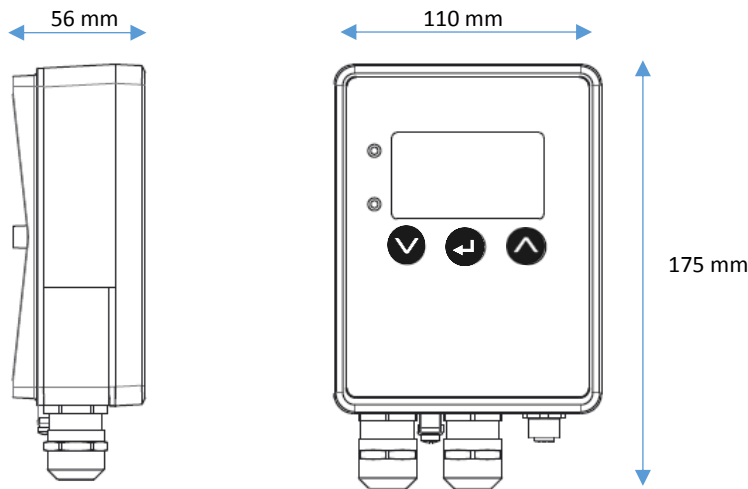

IY.Ex-D.... (DUCT/KANAL)

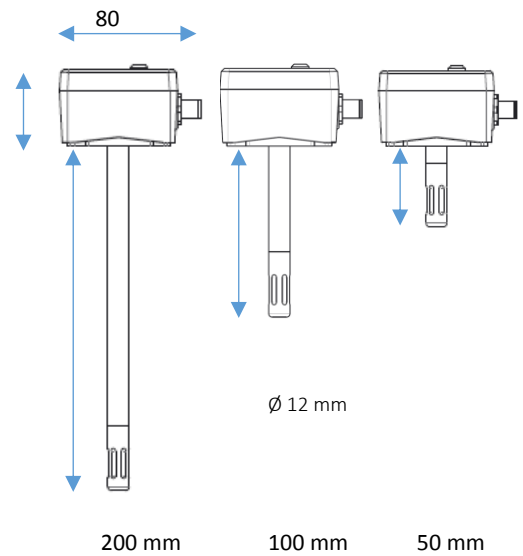

IY.Ex-P.... (PRESSURE/DRUCK)

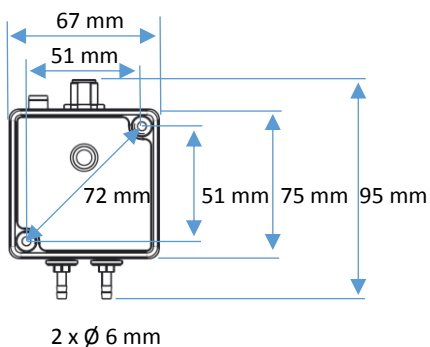

IY.Ex-R.... (ROOM/RAUM)

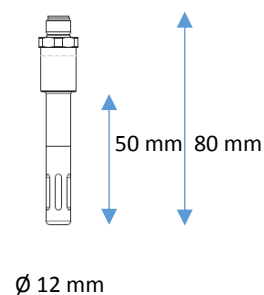

5. Assembly / Installation

UNLOCK ELECTRONIC



Switch off power and check

- Press down release tab carefully
- Slide electronic module up and
- Remove forward

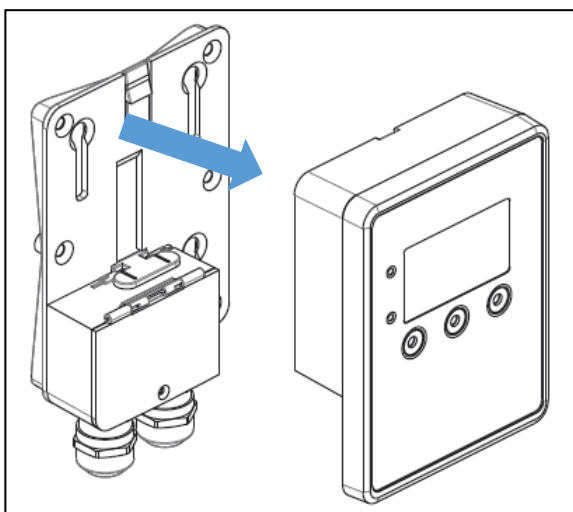
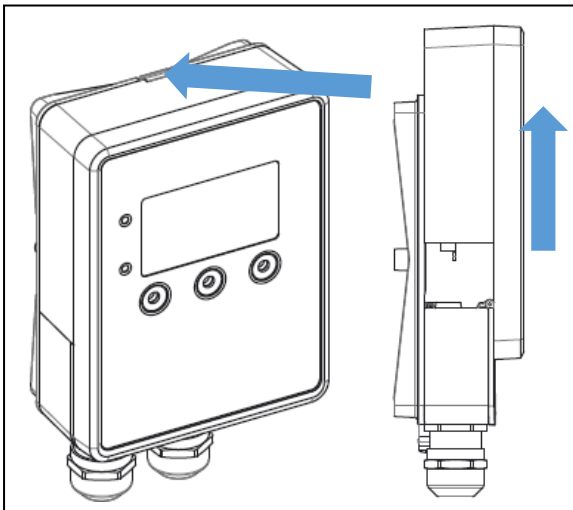

WALL MOUNTING

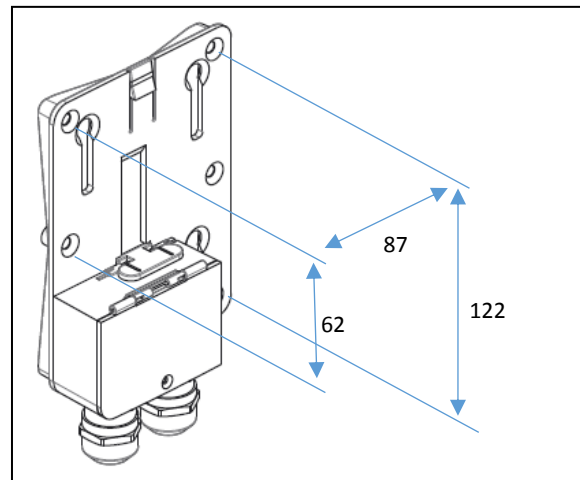

DUCT MOUNTING

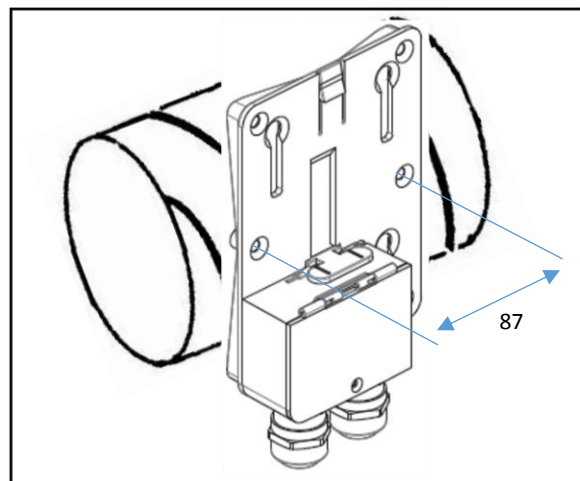

MOUNTING FRAME

- Drill holes according to the drilling plan (see illustration)
- Mount base frame with delivered screws.
- Make sure when mounting that the mounting frame is not under strain or sags
- For outdoor mounting make sure that no water accumulates or frost can form

ELECTRICAL CONNECTION

The integrated electrical connection box protection type Ex e enables direct contact to the supply and the analog outputs. According to IEC 61010-1, protect the supply in the case of a fault against excessive high power consumption from the mains with a fuse.

- Switch off power and check
- Unlock electronic part
- Remove M3 screw from cover
- Open cover
- Remove protection of the cable connection
- Insert cable
- Strip cable (6 mm)
- Open clamp by pressing gently with a screwdriver
- Slide wire/s in
- Remove screwdriver
- Close cover
- Tighten cable screws
- Close unused opening with blind plugs

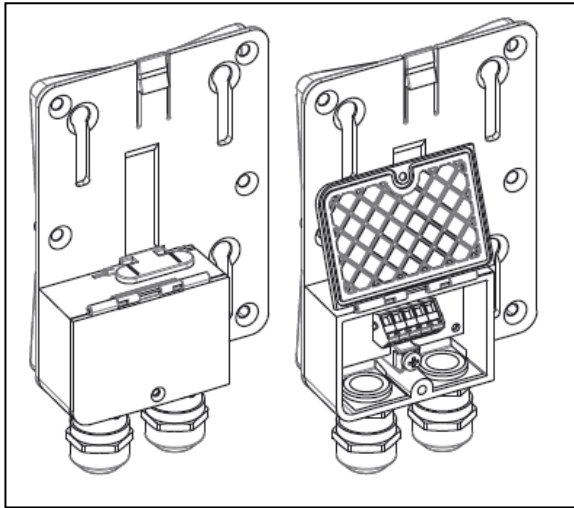

WIRING DIAGRAM

- Terminal 1(+), 2(-) Supply
- Terminal 3, 4 (GND) Channel 1
- Terminal 5, 4 (GND) Channel 2

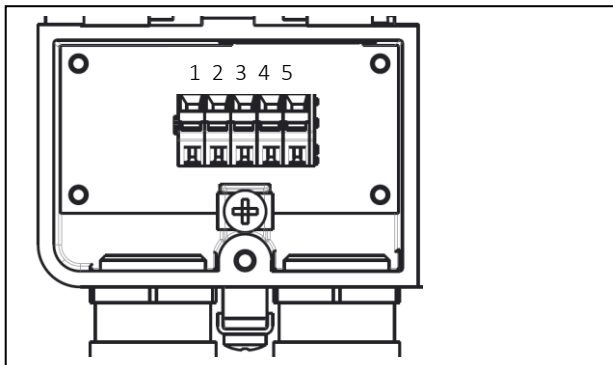

LOCK ELECTRONIC

- Attach electronic part
- Lock by sliding together

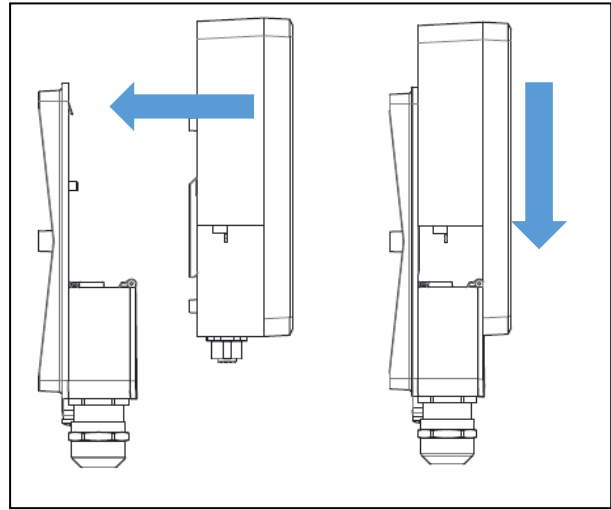

MOUNTING PROBE/FEELER

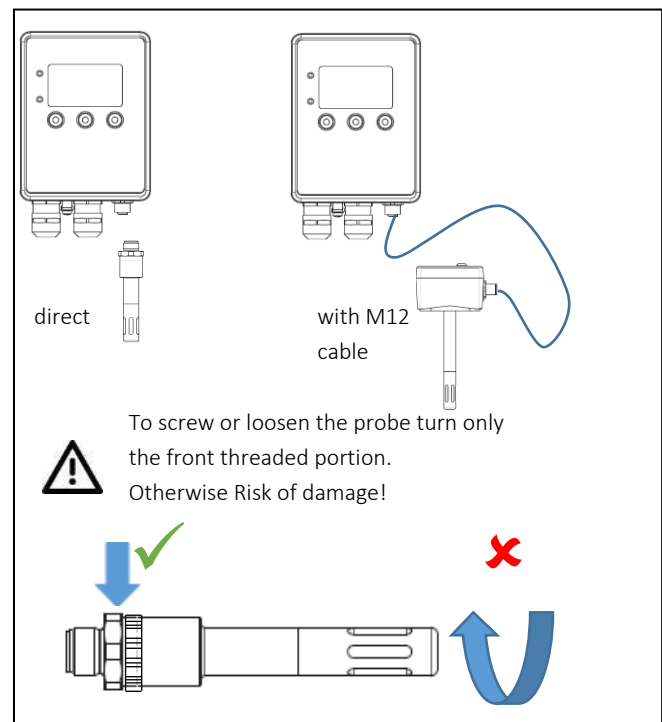

Installation of a fixed probe/feeler:

- The transducer must be installed so that the feeler/probe is facing down!

Mounting a remote probe/feeler:

- Using a pluggable connection cable, the probe/feeler can be located up to 100 m.
- The probe/feeler must be mounted so that no moisture can enter. If possible, a drip should be fitted for each assembly
- The connection cable must be shielded

6. Commissioning

Make sure that the device is properly installed in accordance with the preceding chapters and has been connected and the power supply with the specifications on the nameplate.

Turn on the power supply.

- Display switches to normal
- Sensor data loads
- LED lights green when probe/feelers connected and within the set measuring range.

7. Operation

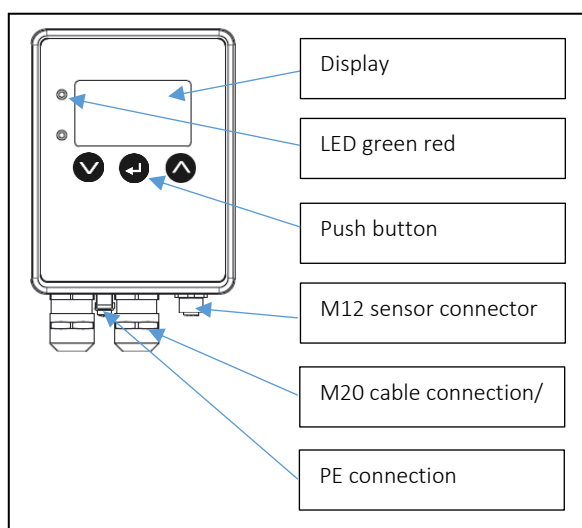

8. Dismantling

- Disconnect power and check
- Press down release tab carefully
- Slide out electronics module
- Open the terminal box
- Remove cable

9. Calibration analog outputs

The TR.Ex has the menu item "Output calibration" a function in the analog outputs can be checked / calibrated.

In parameterization mode (see Chapter 10) can be preselected volts or milliamps. Using the arrow keys, you can now define the desired output value at the outputs.

Based on the measurement results can be the deviation setpoint / actual value in the simplest way.

$$\text{deviation in \%} = \frac{\text{setpoint} - \text{actual value}}{\text{scale value}} \times 100 \%$$

Setpoint value	via the menu
Actual value	value analog output
Scale value	most 10V or 20mA

e.g.

$$\text{deviation in \%} = \frac{12 \text{ mA} - 11,95 \text{ mA}}{20 \text{ mA}} \times 100 \% = 0,25 \%$$

10. Parameterization

	ACTION	DISPLAY	ACTION	DISPLAY	ACTION	DESCRIPTION	ACTION
PARAMETER MODE							
	⬇					Push 3 seconds	
LANGUAGE SETTING							
	⬇ ⬆	D Deutsch GB English F Francais E Espanol I Italiano	⬇			Select using keys desired language press enter	
SENSOR SETTING							
⬇	⬇	Output mA / Volt	⬇	mA Volt	⬇ ⬆	Select mA or Volt at the output channels 1 / 2	⬇
	⬇	Select sensor	⬇	temperature relative humidity dew point pressure	⬇ ⬆	Select sensor for next steps	⬇
	⬇	Select unit	⬇	°C, °F, K, °Ra, %rF, % rH Pa, mbar,	⬇ ⬆	Define unit	⬇
	⬇	Measurement range	⬇	0,00 100	⬇ ⬆	Measuring range lower - upper limit	⬇
	⬇	Offset	⬇	0,000	⬇ ⬆	Set Offset	⬇
	⬇	Select channel	⬇	Channel 1 Channel 2	⬇ ⬆	Which channel should be output	⬇
	⬇	Output range	⬇	4,00 20,00	⬇ ⬆	Scaling from - to	⬇
	⬇	Output	⬇	normal invers	⬇ ⬆		⬇
	⬇	Sensor error	⬇	0 20	⬇ ⬆	Output signal in case of failure	⬇
	⬇	Damping	⬇	1 50	⬇ ⬆	1 = no damping 50 = 5 seconds	⬇
	⬇	Zero compensation	⬇		⬇ ⬆	Pressure connection short circuit	⬇
	⬇	k-Factor	⬇	1 10000	⬇ ⬆	k=0 no VAV measurement	⬇
				back to main			
FACTORY SETTING							
⬇	⬇	Factory settings		Load factory settings Back to main menu	⬇ ⬆		⬇
OUTPUT CALIBRATION							
⬇	⬇	Output		mA Volt	⬇ ⬆	Set values are to be measured on channel 1 and 2	⬇
		Value		0,0 20,0			
PASSWORD							
⬇	⬇	Password	⬇	0 0 0 0	⬇ ⬆		⬇
		Save Password		Yes / no			
DISPLAY							
⬇	⬇	Display	⬇	Light on Light off	⬇ ⬆		⬇
SAVE							
	⬇	Save	⬇	Save Discard Back to main menu	⬇ ⬆		⬇

11. Error Message

No Display / LED

- Check power supply
- Check if mounting frame and electronics are locked

No output signal

- Check power supply (LED red/green)
- Check wiring
- Check parameterizing

Red LED

- Reading out of range
- Sensor line break

12. Maintenance

The device is maintenance free annual function testing and regular cleaning of dust and dirt with a damp cloth is recommended.

13. Repair

Return of a device to claim services. The installation and operation of the TR.Ex in accordance with this manual are very unproblematic. Should the unlikely event occur that a device has to be returned for repair or testing to our service department, a return form is provided under "service address" on the last page.

14. Disposal

Every year, thousands of tons of polluting electronic components land on landfills around the world. To ensure the best possible disposal or recovery of electronic components, the European Union has adopted the WEEE Directive. (Waste Electrical and Electronic Equipment) Please return these products directly to us at the end of their lifecycle so that we can dispose of them properly. The WEEE is an important contribution to the environment and we are happy to help protect the environment with this disposal concept.

15. Accessories Spare Parts

TITLE

Filter cap pore size 10 µm	FK.Va-10
1 m M12 cable for remote measurement	KV.Pu-1m
5 m M12 cable for remote measurement	KV.Pu-5m
10 m M12 cable for remote measurement	KV.Pu-10m
Cable glands M20x1,5 Ms/Ni incl. nut	KL.Ms-20
Pressure connector M5 to tube 6 mm Package Contents 2 pieces	DA.Ms-M5-6 (Standard)
Pressure connector M5 to tube 4 mm Package Contents 2 pieces	DA.Ms-M5-4
M5 thread enlargement to 1/8" Package Contents 2 pieces	GW.Va-M5-G1/8
M5 thread enlargement to 1/4" Package Contents 2 pieces	GW.Va-M5-G1/4
1/8" clamp fitting to 6 mm tube V4A	SR.Va-1/8-6
1/8" clamp fitting to 8 mm tube V4A	SR.Va-1/8-8
M12 female and M12 male 5 pole, shielded Connector set. PG9	CS.Ms-M12FM

Revision Status

VERSION	DATE	SUPPLEMENT / CHANGE / NOTE
01	2015-09-30	First Edition
02	2016-03-16	Volume flow and dew point
03	2016-04-20	Adapt new ATEX guideline
04	2016-05-06	Rename to IY.Ex
05	2018-07-19	Include dimensions

EU Konformitätserklärung EU Declaration of Conformity Déclaration de Conformité UE

petz industries GmbH & Co. KG ▪ Mühlenweg 2 ▪ 96358 Teuschnitz / Haßlach ▪ Germany

erklärt als Hersteller in alleiniger Verantwortung, dass das Produkt
declares as manufacturer under sole responsibility that the product
déclare sous sa seule responsabilité en qualité de fabricant que le produit

TR.Ex
IY.Ex

den Vorschriften folgender Europäischer Richtlinien durch Anwendung harmonisierter Normen entspricht:
conforms with the provisions of the following European Directives by applying the harmonised standards:
est conforme aux prescriptions des Directives Européennes suivantes par l'application des normes harmonisées :

Richtlinien/Directives/Directives		Normen/Standards/Normes		Ex-Normen/Ex-Standards/Normes Ex	
2014/35/EU	(LVD)	EN 61010-1	(2010)	EN 60079-0	(2014)
2014/30/EU	(EMC)	EN 60529	(2012)	EN 60079-7	(2007)
2014/34/EU	(ATEX)	EN 61326-1	(2006)	EN 60079-11	(2012)
2012/19/EU	(WEEE)	EN 61326-2-3	(2006)	EN 60079-18	(2015)
2011/65/EU	(RoHS)	EN 55011 Class A	(2016)	EN 60079-26	(2007)
		EN 50581	(2012)	EN 60079-31	(2009)
EG-Baumusterprüfbescheinigung Nr: EC-Type Examination Certificate No: Numéro de l'attestation d'examen CE de type:		Transmitter		EPS 14 ATEX 1 789 X	
				II 2(1)G Ex eb mb ib [ia Ga] IIC T4	(Gb)
				II 2(1)D Ex tb [iaD] IIIC 130 °C	(Db)
		Sensor		II 1/2G Ex ia IIC T6/T5/T4	(Ga/Gb)
				II 1/2D Ex ia IIIC 130 °C	(Da/Db)

Benannte Stelle Qualitätssicherung
Notified Body Quality assurance
Organisme Notifié Système d'assurance qualité

Bureau Veritas / 2004

Nürnberg, 20. April 2016
petz industries GmbH & Co. KG



Rolf Petz
Geschäftsführer
Managing director
Le Directeur



Thomas Kellermann
Explosionsschutzbeauftragter
Explosion Protection Supervisor
Contrôleur de la protection Explosion

Contact Information

Company Information

PRODUCTION

petz industries GmbH & Co. KG
Mühlenweg 2
96358 Teuschnitz / Haßlach
Germany
Phone +49 9268 971 0
Fax +49 9268 676 0
Email pi@pi-global.de
Internet www.pi-safety-components.com

TECHNICAL SUPPORT

GERMANY:

Phone: +49 911 658 18 60
Telefax: +49 911 658 18 88
E-Mail: pi@pi-global.de

SALES

petz industries GmbH & Co. KG
Flachsländer Straße 8
90431 Nürnberg
Germany
Phone +49 911 658 18 60
Fax +49 911 658 18 88
Email pi@pi-global.de
Internet www.pi-safety-components.com

